

**EXPERIMENTAL AND NUMERICAL ANALYSIS OF ALUMINIUM  
ALLOY FATIGUE LIFETIME UNDER COMBINED CYCLIC BENDING -  
TORSION LOADING**

Milan UHRÍČIK<sup>1</sup>, Peter KOPAS<sup>2</sup>, Peter PALČEK<sup>1</sup>

<sup>1</sup>Department of Materials Engineering, Faculty of Mechanical Engineering, University of Žilina

<sup>2</sup>Department of Applied Mechanics, Faculty of Mechanical Engineering, University of Žilina

### **1. Introduction**

Fatigue failure is an extremely complex physical process which is governed by a great number of parameters related to, for example, local geometry and material properties of the structural region surrounding the crack growth path. It is commonly recognized that it is impossible for a physical model to account for all fatigue influencing parameters, thus a lot of approximate models have been conceived for practical fatigue assessments. In every stadium of fatigue cumulative damage dominates a definite mechanism controlled by more or less known and verified rules. There exists the stage of micro-plastic process in total volume of material with following stage of fatigue crack nucleation and stage of their growing with more or less detailed zoning. Despite of this research no results have been achieved, which could be considered as successful ones. This applies mainly to the cases of random and combined stress, where today's procedures used in one axis stress analysis fails. There are different approaches and methods which can be used in fatigue life predictions [1, 2]. Fatigue under combined loading is a complex problem. A rational approach might be considered again for fatigue crack nucleation at the material surface [3]. The state of stress at the surface is two-dimensional because the third principal stress perpendicular to the material surface is zero. Another relatively simple combination of different loads is offered by an axle loaded under combined bending and torsion. This loading combination was tested in our and also in many others experiments [4, 5, 6]. In spite of this fact, fatigue mechanisms are still not fully understood. This is partly due to the complex geometrical shapes and also complex loadings of engineering components and structures which result in multiaxial cyclic stress-strain states rather than uniaxial.

The strength analysis of welded structures does not deviate much from that for other types of structures. Various failure mechanisms have to be avoided through appropriate design, choice of material, and structural dimensions. Design criteria such as yielding, buckling, creep, corrosion, and fatigue must be carefully checked for specific loading conditions and environments. It is, however, a fact that welded joints are particularly vulnerable to fatigue damage when subjected to repetitive loading. Fatigue cracks may initiate and grow in the vicinity of the welds during service life even if the dynamic stresses are modest and well below the yield limit. The problem becomes very pronounced if the structure is optimized by the choice of high strength steel. The very reason for this choice is to allow for higher stresses and reduced dimensions, taking benefits of the high strength material with respect to the yield criterion. However, the fatigue strength of a welded joint is not primarily governed by the strength of the base material of the joining members; the governing parameters are mainly the global and local geometry of the joint. Hence, the yield stress is increased, but the fatigue strength does not improve significantly. This makes the fatigue criterion a major issue. The fatigue strength will alone give the requirements for the final dimensions of the structural members such as plates and stiffeners. To overlook this fact may result in fatigue failure and serious consequences [7, 8]. As already stated, the fatigue behavior of welded joints is random by nature. Very few load-bearing details exhibit such large scatter in fatigue life as welded joints. This is true even in controlled laboratory conditions. As a consequence, it becomes an important issue to take scatter into consideration, both for the fatigue process and for the final life. Furthermore, the in-service stresses may often be characterized as stochastic processes.

There has been a trend the last two decades to treat the strength problem of a structure by applying statistics and probability calculations. As a consequence, the probability of failure is used as a criterion, instead of the more traditional safety factors, when checking various design criteria. The methods and tools for performing this type of analysis have become available and quite easy to use. The probability of no failure during a given time period is considered to be the reliability of the structure. The methods used for determining the probability are often called reliability methods. Furthermore, if the associated probability of failure is weighed against the consequence of failure we arrive at the risk concept. Achieving high reliability and low risk levels will maintain operational capability and secure life and assets. The more sources of uncertainty there are in a structural problem, the more appropriate will be the application of a reliability approach. For processes where damage is accumulating with time, the probability of failure will increase with service time, depending on decisions made for the design concept, configurations, dimensions, material properties, and in-service inspection strategy.

For fatigue of welded joints the following sources of uncertainty are dominant [9, 10]: the material parameters, the global and local geometry of the joint, the service stress history and the performance of the in-service inspection.

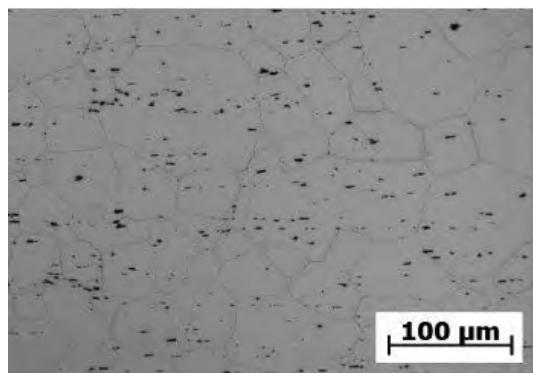
## 2. Experimental material

This research was conducted on an aluminium alloy EN AW 6063.T66 (AlMgSi07.F25). It is a medium strength alloy, suitable for applications where no special strength properties are required. Simple to complex shapes can be produced with very good surface quality characteristics, and suitable for many coating operations such as anodizing and powder coating. Typical areas of application for this alloy is architectural doors and windows, facades, furniture parts, lighting columns and flagpoles, heat sink sections, office equipment, trailer flooring, irrigation, heating and cooling pipes, ladders, railings. The T66 treatment corresponds to solution heat-treated and then artificially aged (precipitation hardened) to a higher level of mechanical properties through special control of manufacturing process. Such a heat treatment conditions make mechanical property level higher than T6 heat treatment conditions. The typical chemical composition of this aluminium alloy is shown in Table 1. The high Magnesium content is responsible for the high corrosion resistance and good weld ability. The material used in this research was delivered in the form of cylindrical shape with a diameter 10 mm. The length of cylindrical bars was 150 mm. The material was in rolled state.

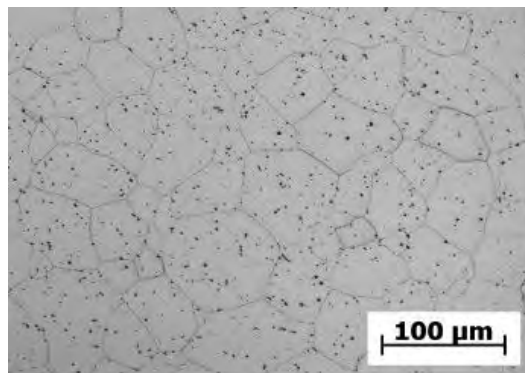
**Table 1** Chemical composition of the aluminium alloy EN AW 6063.T66

| Cu   | Cr   | Fe   | Mg        | Mn   | Si        | Zn   | Ti   | other |       | Al   |
|------|------|------|-----------|------|-----------|------|------|-------|-------|------|
|      |      |      |           |      |           |      |      | each  | total |      |
| 0.10 | 0.10 | 0.35 | 0.45-0.90 | 0.10 | 0.20-0.60 | 0.10 | 0.10 | 0.05  | 0.15  | rest |

Figure 1 and Figure 2 illustrates a typical microstructure of the aluminium alloy evaluated in longitudinal and transversal direction. It is visible the stretched grains due to the rolling process. Also, a dispersed second phase typical of deformed and heat treated wrought aluminium alloys is observed.

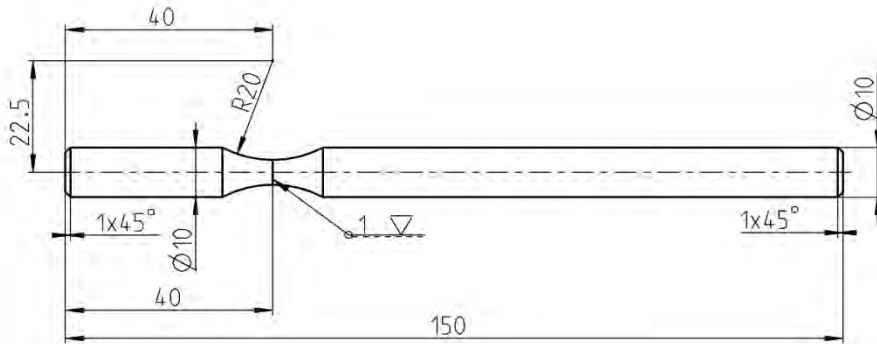


**Fig. 1** Microstructure of the aluminium alloy EN AW 6063.T66 according the rolling direction, etch. 0.5 % HF



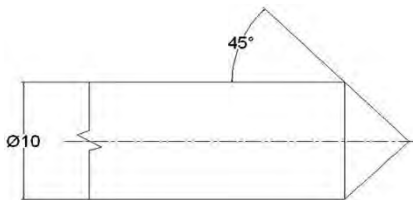
**Fig. 2** Microstructure of the aluminium alloy EN AW 6063.T66 transversal the rolling direction, etch. 0.5 % HF

Welding was conducted by the tungsten-inert gas (TIG) welding method using by Fronius Magic Wave 2200 welding machine. The welding factors used were: welding current  $I_z = 79$  A; welding voltage  $U_z = 18,8$  V; diameter of wolfram electrode  $\varnothing = 2,4$  mm; welding gas Ar 99,996 % with gas flow  $Q = 15$  l.min<sup>-1</sup>. As a welding wire material there was used aluminium wire AISi5 with diameter 2 mm. The joint strength of TIG-welded joints was evaluated by fatigue testing, using the test specimens shown in Figure 3.

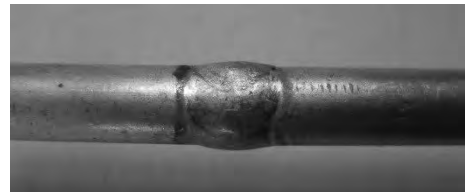


**Fig. 3** Shape and dimension fatigue test specimen (dimension in mm)

The joint geometry of the rod used for welding process is shown in Figure 4. Figure 5 illustrate final shape of welded joint.



**Fig. 4** Joint geometry (dimension in mm)



**Fig. 5** Shape of welded joint

### 3.Chosen criteria for multiaxial fatigue damage prediction

There are plenty of hypotheses used for evaluating a degree of damage caused by variable load [12, 13]. Life prediction methods which presume homogeneous material (free from cracks, inclusions or defects) at the outset of the investigation can be divided into strain-based (low-cycle fatigue) and stress-based (high-cycle fatigue) methods. Low-cycle fatigue is characterized by repeated plastic strains during cyclic loading conditions where fatigue failure occurs after relative low number of load cycles (in the order of  $10^4$  cycles). This design approach is normally used in fatigue assessment of local areas where high stress concentrations exist and the material response locally is repeated plastic deformation. In addition, stress-based approaches use the elastic stress range (or amplitude) as the governing load parameter. At a sufficient load level, which may result in

a fatigue life of approximately  $10^7$  cycles, a threshold referred to as the fatigue or endurance limit can be seen for many materials. Research of mechanism and processes of fatigue failure of materials achieves great advance, however there still doesn't exist general failure model, which should be applicable for different conditions of activity. There is needed an integration for such a procedures into a modern systems of computing aided design (CAD) in relationship to methods of strength computing transferred by finite element method (FEM) [14, 15].

Fatemi and Socie [16] observed that the Brown and Miller's idea could be successfully employed even by using the maximum stress normal to the critical plane, because the growth rate mainly depends on the stress component normal to the fatigue crack. Starting from this assumption, he proposed two different formulations according to the crack growth mechanism: when the crack propagation is mainly MODE I dominated, then the critical plane is the one that experiences the maximum normal stress amplitude and the fatigue lifetime can be calculated by means of the uniaxial Manson-Coffin curve; on the other hand, when the growth is mainly MODE II governed, the critical plane is that of maximum shear stress amplitude and the fatigue life can be estimated by using the torsion Manson-Coffin curve. Criterion has the following form:

$$\frac{\Delta\gamma}{2} \times \left( 1 + k \times \frac{\sigma_{n,max}}{\sigma_y} \right) = \frac{\tau_f'}{G} \times (2 \times N_f)^{b\gamma} + \gamma_f' \times (2 \times N_f)^{c\gamma} \quad (1)$$

Smith, Watson and Topper (SWT) created a parameter for multiaxial load, which is based on the main deformation range  $\Delta\varepsilon_1$  and maximum stress  $\sigma_{n,max}$  to the main plane. Criterion has the following form:

$$\sigma_{n,max} \times \frac{\Delta\varepsilon_1}{2} = \frac{\sigma_f'^2}{E} \times (2 \times N_f)^{2b} + \sigma_f' \times \varepsilon_f' \times (2 \times N_f)^{b+c} \quad (2)$$

Brown and Miller [12] observed that the fatigue life prediction could be performed by considering the strain components normal and tangential to the crack initiation plane. Moreover, the multiaxial fatigue damage depends on the crack growth direction. Different criteria are required if the crack grows on the component surface or inside the material. In the first case they proposed a relationship based on a combined use of a critical plane approach and a modified Manson-Coffin equation, where the critical plane is the one of maximum shear strain amplitude. Criterion which was created has the following form:

$$\frac{\Delta\gamma_{max}}{2} + S \times \Delta\varepsilon_n = A \times \frac{\sigma_f' - 2 \times \sigma_{n,mean}}{E} \times (2 \times N_f)^b + B \times \varepsilon_f' \times (2 \times N_f)^c \quad (3)$$

Liu created a virtual model of the deformation energy, which is a generalization of the axial energy on the basis of prediction of fatigue life. Criterion has the following form:

$$\Delta W = 4 \times \sigma_f' \times \varepsilon_f' \times (2 \times N_f)^{b+c} + \frac{4 \times \sigma_f'^2}{E} \times (2 \times N_f)^{2b} \quad (4)$$

where:

|                              |  |                    |   |
|------------------------------|--|--------------------|---|
| $\gamma_f'$ .....            | the fatigue ductility coefficient in torsion | $\Delta W$ .....   | the virtual strain energy                 |
| $\varepsilon_f'$ .....       | the fatigue ductility coefficient            | $b$ .....          | the fatigue strength exponent             |
| $\sigma_f'$ .....            | the fatigue strength coefficient             | $b_\gamma$ .....   | the fatigue strength exponent in torsion  |
| $\sigma_{n,mean}$ .....      | the mean stress                              | $c$ .....          | the fatigue ductility exponent            |
| $\sigma_y$ .....             | the stress in the direction of the axis y    | $c_\gamma$ .....   | the fatigue ductility exponent in torsion |
| $\tau_f'$ .....              | the fatigue strength coefficient in torsion  | $N_f$ .....        | the number of cycles to fracture          |
| $\Delta y$ .....             | the shear strain range                       | $A, B, S, k$ ..... | material parameters                       |
| $\Delta y_{max}$ .....       | the maximum shear strain range               | $E$ .....          | the elasticity modulus in tension         |
| $\Delta \varepsilon_n$ ..... | the normal strain range                      | $G$ .....          | the elasticity modulus in torsion         |

#### 4. Experimental and numerical results

Thirty smooth specimens were tested under strain controlled conditions in order to identify the strain-life behaviour of the experimental material. After machining, the specimen surfaces were mechanically polished. The experiments were carried out in an electro mechanic fatigue test machine, developed on University of Žilina. Design of experimental equipment has been based on mechanical principle. The constant rotation is generated by excenter and linkage mechanism. By changing of excentric magnitude it is possible to change a loading magnitude. Also if we change a length of connecting crank on the experimental equipment, there will be change in a loading cycle character. Power of device is secured by two synchronic electromotors with frequency converters from 0.5 Hz to 100 Hz. Loading frequencies are identical with frequency of rotation drive. Synchronization of the electromotors is secured using by electronics and allows synchronization of loading amplitudes. Synchronization of electromotors also allows setting phase shift for individual loading levels. There are also included two force measure systems in experimental equipment. These systems may be used for measurement of force values during the loading process. For evaluation of fatigue curves it needs to know stress and strain conditions on individual loading levels. A sinusoidal waveform was used as command signal. The fatigue tests were conducted with constant strain amplitudes, at room temperature, in air. The specimens were cyclic loaded under strain control with symmetrical proportional bending-torsion loading, with a nominal strain ratio,  $R_\varepsilon = -1$ . The computational fatigue tests were performed under in-phase cyclic loading with the zero mean value. All tests were performed under controlled bending and torsion moments. Frequency of each analysis was equal to 30 Hz. The results, fatigue resistance (strain amplitude vs. number of cycles to failure) of tested structural material

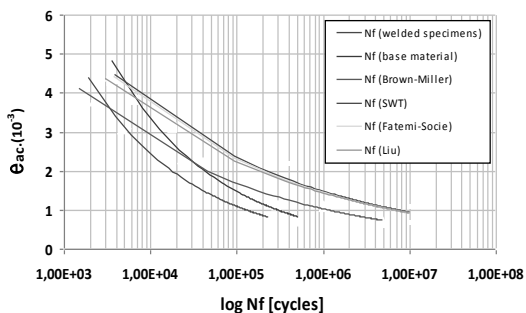
EN AW 6063.T66 before and also after welding process (TIG) in the low cycle regime are presented in Figure 7.

In ANSYS software was created the model of the test bar. The real geometry of this component is shown in Figure 3. The rod bar had a circular shape with a defined section, in which was expected an increased concentration of stress and creation a fatigue fracture. The ends of this model were loaded by reversed bending moment on the one side and by reversed torsion moment on the opposite site. The values of presented stresses and strains in the middle of the rod radius were taken from computational analysis using finite element method. From computational analysis can be seen that the area with greatest concentration of stresses or eventually the place with the higher deformation was localized in the middle of the rod radius (see Figure 6).

Obtained values of the stresses from finite element analysis were next computational analysed using Fatigue Calculator software. This is a program which can quickly calculate fatigue lifetime of selected material. After starting the calculation, Fatigue Calculator displayed the number of cycles to failure for different models of damage. In our calculation we considered with all multiaxial criteria described above which can be applied to low-cycle fatigue region. The computational fatigue tests were performed under in-phase cyclic loading with the zero mean value. Frequency of each analysis was equal to 30 Hz. The results, fatigue durability of EN AW 6063.T66 with different models of damage (stress amplitude vs. number of cycles to failure) in the low-cycle regime are presented in Figure 7.



**Fig. 6** Result of FEM analysis



**Fig. 7** Manson-Coffin curves for multiaxial low-cycle fatigue with phase shift  $0^\circ$

## 5. Conclusion

Generally we can say that results are in good agreement with published results of other authors [8, 9, 10]. Comparing the fatigue curves can be observed, that the curve for the welded specimens gives shorter resistance to fatigue damage than the curve for the base specimens. The decrease in fatigue strength of the welded specimens was attributed to the stress concentration at the toe of weld.

All multiaxial models applied to fatigue lifetime calculation of aluminium alloy EN AW 6063.T66 increases with decreasing stress amplitude continuously in the cycles of number region. Considering the low-cycle region the fatigue curves have shown a good agreement of progress line with Fatemi-Socie, SWT and Liu damage models. For Brown-Miller model it was also observed significant decrease of stress amplitude with increasing number of cycles to failure but the fatigue endurance values in comparison with reference number of cycles were markedly lower as for Fatemi-Socie, SWT and Liu damage multiaxial models.

#### Acknowledgements

*This work has been supported by Scientific Grant Agency of Ministry of Education of Slovak Republic and Slovak Academy of Science, No.1/0797/12 and project EU ITMS 26220220154.*

#### Literature

1. CARPINTERI, A., SPAGNOLI, A., VANTADORI, S. *A multiaxial fatigue criterion for random loading*. Special Issue of Fatigue and Fracture of Engineering Materials and Structures, s.515-522, Vol.26, Nr.6, (2003).
2. BALDA, M., SVOBODA, J., FRÖHLICH, V. *Using hypotheses for calculating fatigue lives of parts exposed to combined random loads*. Engineering Mechanics, s.12-15, Vol.10, Iss.5, (2003).
3. NOVÝ, F., ZATKALÍKOVÁ, V., BOKŮVKA, O., MIKOVÁ, K. *Gigacycle fatigue endurance of marine grade stainless steels with corrosion pits*. Periodica Polytechnica: transportation engineering, s.99-103, Vol.41, Nr.2, (2013).
4. LEGER, J. *Fatigue life testing of crane drive shafts under crane-typical torsional and rotary bending loads*. Schenck Hydropuls Mag., s.8-11, Iss.1, (1989).
5. GOUGH, H. J., POLLARD, H. V. *The strength of metals under combined alternating stresses*. Proc. Inst. Mech. Engrs., s.3-103, Vol.131, (1935).
6. LUKÁŠ, P., KUNZ, L., NAVRÁTILOVÁ, L., BOKŮVKA, O. *Fatigue damage of ultrafine-grain copper in very-high cycle fatigue region*. Materials Science and Engineering A, s.7036-7040, Vol.528, Nr.22-23, (2011).
7. HURTALOVÁ, L., TILLOVÁ, E. *Elimination of the negative effect of FE-rich intermetallic phases in secondary (recycled) aluminium cast alloy*. Manufacturing Technology, s.44-50, Vol.13, Nr.1, (2013).
8. MADDIX, S. J. *Fatigue strength of welded structures*, Second Edition, Woodhead Publishing, UK, ISBN 978-1855730137, (1991).
9. IRVING, B. *Welding the four most popular aluminium alloys*. Weld. J., s.51-55, (1994).
10. BORREGO, L. P., ABREU, L. M., COSTA, J. M., FERREIRA, J. M. *Analysis of low cycle fatigue in AlMgSi aluminium alloys*. Engineering Failure Analysis, s.715-725, Vol.11, (2004).
11. CHU, C. *Multiaxial fatigue life prediction methods in the ground vehicle industry*. Int. J. Fatigue, s.325-330, Vol.19, Nr.1, (1997).
12. BROWN, M. W., MILLER, K. J. *A Theory for fatigue under multiaxial stress-strain conditions*. Proc. Inst. Mech. Engrs., s.745-755, Vol.187, (1973).
13. VAŠKO, A., VAŠKO, M. *Microstructure and mechanical properties of ADI in dependence of transformation temperature*. Process Innovation, s.112-119, (2010).
14. SEGLA, Š. *Dynamic and quasistatic analysis of the elevating work platform*. Journal Mechanisms and Manipulators, s.81-86, Vol.6, Nr.1, (2007).
15. SOCIE, D. F. *Multiaxial fatigue damage models*. J. Eng. Mater. Technol., s.293-298, (1987).
16. FATEMI, A., SOCIE, D. F. *A critical plane approach to multiaxial fatigue damage including out-of-phase loading*. Fatigue Fract. Eng. Mater. Struct., s.149-166, (1988).

Milan Uhrčík, Peter Kopas, Peter Palček: