



OPTIMEX: Measurement of Detonation Velocity with a Passive Optical Fibre System

**Jiri Pachmáň,^{1*} Martin Künzel,² Karel Kubát,¹
Jakub Šelešovský,¹ Roman Maršálek,³ Martin Pospíšil,³
Michal Kubíček,³ Aleš Prokeš³**

¹ *Institute of Energetic Materials, University of Pardubice, Czech Republic*

² *Institute of Energetic Materials, University of Pardubice, OZM Research, Czech Republic*

³ *Department of Radio Electronics, Faculty of Electrical Engineering and Communication, Brno University of Technology, Czech Republic*

*E-mail: jiri@pachman.eu

Abstract: Detonation velocity (VOD) is one of the most important parameters describing the detonation process of a particular explosive. This article summarizes some peculiarities that we have come across when building and testing our new passive optical VOD meter – OPTIMEX. The advantages of using multiple probes with independent signal recording is discussed. The practical issues related to an explosive's translucency are solved. Finally, a new method for detonation velocity data evaluation is proposed and demonstrated.

Keywords: velocity of detonation, VOD, optical fibre, passive VOD measurement, OPTIMEX

1 Introduction

A number of new explosives is proposed or newly synthesized every year. These explosives are characterized to the best capabilities of the authors in terms of chemical purity, theoretical maximum density, heat of combustion, enthalpy of formation and sensitivity. In many cases, these experimental results are then

accompanied by calculated detonation parameters based on different models of detonation. Such models however often assume ideal detonation behaviour. The charge diameter is not considered, nor is the type of initiation or the length to diameter ratio. The small quantity of a newly prepared substance often complicates the experimental verification of the calculated detonation parameters. Despite these complications it is necessary to verify the calculated detonation parameters by reliable experiments.

Probably the most important and best understood parameter describing the detonation process of a particular explosive is its detonation velocity (velocity of detonation, VOD), representing the average velocity at which a detonation wave propagates into an unreacted explosive charge. Many experimental methods for the determination of the VOD exist and are employed in the everyday evaluation of explosives. Improvements in measuring the detonation velocity aim to lower the overall cost, to increase the accuracy and reliability, and, most importantly, to make the measurement simple enough to allow employees with varying educational backgrounds (*e.g.* in a production facility, mines, armed forces, *etc.*) to obtain trustworthy results after only quick training.

VOD is, in simple Chapman-Jouget theory [1, 2], constant for a particular explosive. In practice however it unfortunately depends on a number of aspects, defining not only the explosive itself, but also the entire charge and in certain cases its method of initiation. The following points need to be considered when experimentally determining the detonation velocity:

- Chemical composition of the explosive (including water content)
- Density of the charge
- Diameter of the charge with respect to the critical diameter and the detonation front curvature
- Confinement of the charge
- Length to diameter ratio of the charge
- Type of initiation (point *vs.* plane wave, distance of sensor from initiation)
- Method of VOD determination and its limits
 - Inherent accuracy
 - Sensor positioning
 - Interference of sensors with the detonation wave

The detonation velocity may be measured by a number of different techniques, all of which have their strengths and weaknesses. A nice review was published by Sućeska [3], and more recently by Tete [4]. The methods may in general be divided into two groups, continuous and discontinuous. The first group covers techniques that continually measure the course of a detonation wave propagation by following the change of a suitable property (resistance of

an embedded probe, time for reflection from the end of a coaxial cable – time-domain reflectometry, frequency of Doppler shifted light, light emission acquired by a streak camera, *etc.*). These methods (excluding the streak camera) are mostly suitable for large diameter charges of bulk loaded explosives. Typical applications are in the determination of VOD in boreholes at mining and quarrying operations. The discontinuous methods are based on measurement of the time taken by the detonation wave to travel between two or more positions in the explosive. This time is evaluated from the response of two or more sensors, placed perpendicularly into the charge at known distances, to the passing of the detonation wave. A number of different sensors was tested in the past, including shorting pins or strips, ionization probes, piezoelectric probes or optical probes. As these sensors may be relatively small in size compared to the charge diameter, they are more suitable for smaller diameter charges, pressed charges, charges of plastic explosives or cartridges. Apart from the invasive sensors, it is also possible to look at the surface of the charge and determine VOD by high speed cameras.

Passive fibre optical probes present, in our opinion, the best option for point to point measurement of VOD, because they are extremely resistant to electrical noise and environmental conditions (rain, snow), are easy to set up and are cheap (a variety of standard telecommunication cables can be used). Commercial unavailability of a reliable system led us to developing a device of our own.

The origin of light produced during detonation was studied by Blackburn and Seely [5]. The detonation front produces a short bright flash, followed by an intense light from a shockwave running in the surrounding air. This secondary light can cause problems in measurements using optical probes.

There are not that many articles describing the measuring technique in the open literature. One of the methods uses optical fibres inserted into the charge and recording the output directly with a streak camera. Lu [6] used plastic optical fibres (2.2 mm outer diameter, 1 mm acrylic core) and a streak camera to measure the detonation velocity of a plastic PETN-based explosive. A multifibre optical probe (strip with 64 fibres, 0.25 mm in diameter) was used for the determination of detonation velocity by Mendes *et al.* [7-9]. The fibres were placed perpendicularly to the charge and their output was recorded by a streak camera.

Alternatively, the optical signal can be converted to an electric signal and recorded with an oscilloscope. Schulz [10] described using an optical cable (16 fibres) and an oscilloscope to measure VOD of an explosive in a borehole. VOD of a PETN film was measured by Cui and Li [11] using quartz fibres and an oscilloscope. Presles *et al.* [12] described using optical fibres to determine VOD of ammonium nitrate. Four sensors placed perpendicularly to the charge

axis were used, the optical signal was transferred by phototransistor and the electrical signal was recorded on an oscilloscope.

The use of a single fibre with holes placed along the axis of the charge was reported by Prinse [13] and Chan [14]. Oscilloscopes were also used in these cases for data acquisition.

Despite the positives, there are some peculiarities that one needs to be aware of when using optical cables. This article tries to summarize those that we have come across when building and testing our new VOD meter – OPTIMEX. The use of plastic or glass fibres is discussed; various methods of experimental design are presented along with the evaluation of the signals obtained. All of the measurements were carried out using various development versions of OPTIMEX – a new device for studying the detonation characteristics of explosives by passive optical probes.

2 Experimental

The OPTIMEX measuring system is described in this section followed by some typical experiments addressing points from the introductory section. Experiments 1 and 2 illustrate the differences between an ideal and not so ideal explosive and also the difference between using separate measuring channels and an optical splitter. Experiment 3 illustrates the translucency of some explosives and the problems related to this phenomenon. The final Experiment 4 describes the possibilities of using the slope of the position-time dependency to determine VOD.

OPTIMEX device

The OPTIMEX system employed in this work was a development version equipped with 8 glass multimode 62.5/125 μm fibres, with ST connectors at the end passing into the device and simply cut with scissors at the end passing into the fibre-holding window. Figure 1 shows a more recent development version with 4 ports for plastic and 4 for glass fibres.

A block schematic of an 8-channel OPTIMEX system is shown in Figure 2. The system consists of three main functional subsystems located on three jointly connected printed circuit boards – an analogue front-end subsystem, a digitizer subsystem and a microprocessor/microcontroller subsystem. The analogue front-end subsystem converts the emitted optical signals to electrical analogue signals by passing through a set of optical/electrical converters, amplifiers and low-pass filter components in each of the 8 channels. In the digitizer board, the analogue electrical signals are then sampled by dual-channel Analogue/

Digital converters (ADC). The digital data are stored into the internal memory of a Field Programmable Gate Array (FPGA) of the Xilinx Artix-7 family. The system is equipped with 12-bit ADCs with sampling rates of 250 MSa/s (4 ns time resolution), necessary for VOD measurements of fast detonating energetic materials or *e.g.* for front curvature measurements, but it is possible to slow down the sampling rate through digital decimation down to 5 kSa/s (*i.e.*, 200 μ s time resolution) for applications requiring longer time records but lower time resolution. Note that 12 bits of ADC resolution corresponds to $2^{12} = 4096$ levels of quantized signal intensity.



Figure 1. OPTIMEX 4+4 system during outdoor trials (left) and final prototype of the handheld 4+4 version (right) complemented with a graphical display and keyboard as a user interface

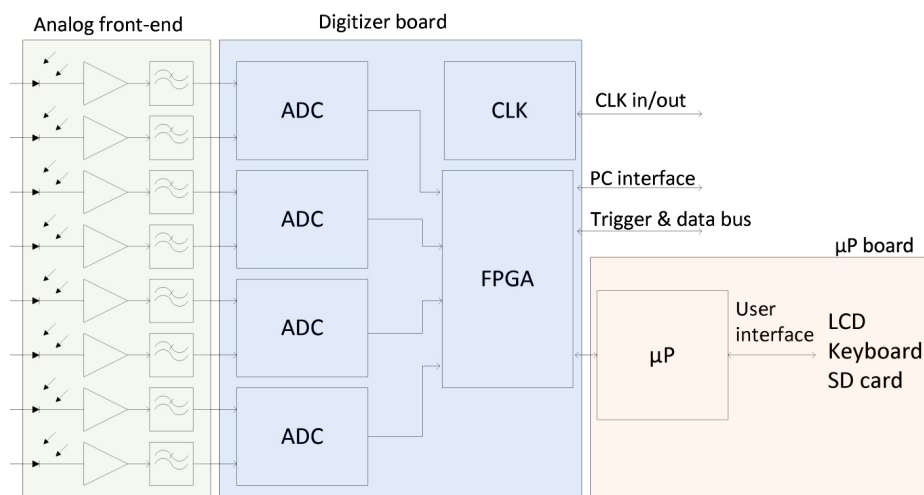

Figure 2. Block schematic of the 8-channel measurement system OPTIMEX

The data can be communicated to the user through a user interface served by the microprocessor (μP) board. The μP board also serves for the setup of measurement parameters, such as triggering modes (*i.e.*, the data acquisition could be triggered by any of the data input channels, a selected input channel or even by an external electrical event), a pre-trigger time interval, vector of distances between the measurement probes *etc.*

Besides the handheld version of the OPTIMEX system with 8 input optical channels, a modular scientific version has also been developed. In such a modular platform, N digitizer boards can be connected through a common data and trigger bus and clocked by a common clock (CLK) signal in order to coherently measure the optical information from $8N$ fibres.

Fibre type

The most common type of plastic optical fibre (POF) in civil applications is a step-index fibre consisting of a 980- μm diameter polymethylmethacrylate (PMMA) core, a 1000- μm diameter fluorinated polymer cladding and polyethylene (PE) jacketing. The advantages of POFs are commercial availability, extremely simple installation that does not require any special tools (can be cut with a sharp knife or razor blade) or training for proper fibre cutting and connecting. The relatively thick jacketing provides good protection against mechanical damage. The thick 1 mm core provides enough light from all types of explosives. Disadvantages are the thickness of the fibre (2 mm is too much for some applications) and relatively high attenuation compared to glass fibres.

Glass optical fibres (GOFs) and accessories are massively employed in telecommunication applications and their price is no longer a limiting factor. GOFs are available in numerous variations, including single-mode and multi-mode versions of varying diameters. They are available in cables with 4, 8, 16 and practically any number of fibres in one cable. Splitting or coupling the signals is done simply by adding passive, commercially available, components. One analogue to digital converter can therefore, in theory, be used for two or more signals. The disadvantages are their lower mechanical robustness and, in the case of some explosives, low light gain requiring adjustment of the attenuation on the light detectors.

3 Measurement Techniques

The acquisition of the entire light course combined with the use of multiple optical fibres provides the ability to use various experimental arrangements. A single

fibre, going in and out of the explosive forming a “meander”, can be used when there is a need for a low number of measuring channels. A similar single channel acquisition technique may be used with perforated fibre probes; multiple fibre probes may also be used resulting in the acquisition of a number of signals not being limited by the number of a digitizer inputs. Further multiplexing may in some cases be introduced using optical splitters when there is a need for a high number of probes.

Experimental setup

Using a separate channel for each measured position in the charge is the simplest case (Experiment 1). However the number of channels can be a limiting factor, especially if one plans to use an oscilloscope (often equipped with only 4 channels) as the data acquisition (DAQ) unit. A higher number of channels needs a recording device with more inputs (OPTIMEX has eight channels in the handheld version and up to 64 channels in the table-top version), or some signals may be multiplexed together. The latter can be easily realized for glass fibres using commercially available passive optical splitters (Experiment 2). Splitters for plastic optical fibres are not so common, but are available.

Another option for how to “increase” the number of measurement locations within a single channel, is to use a single optical fibre with several cavities at known distances from the fibre tip. This type of sensor, called “FOP” (fibre optical probe) is placed longitudinally along the charge axis with the tip of the probe facing the incoming detonation wave. The air in the cavities is shock compressed upon interaction with the wave and emits a light pulse. A small disadvantage of this approach is the decreasing intensity of the signal towards the probe tip due to the damage induced to the fibre by the introduction of the cavities.

The so-called “meander” technique can be used instead in cases when it is possible to take the fibre in and out of the charge. The fibre is threaded through the charge, perpendicular to the axis, as shown in Figure 3 during the determination of VOD of sheet explosive.

All of the methods used to increase the number of measured positions in the charge while maintaining the number of DAQ channels suffer from either lower readability of the data, the signals may partially overlap or the origin of a particular peak may not be so clear. This is more often the case with explosives showing “not so ideal” behaviour, *e.g.* emulsion explosives.

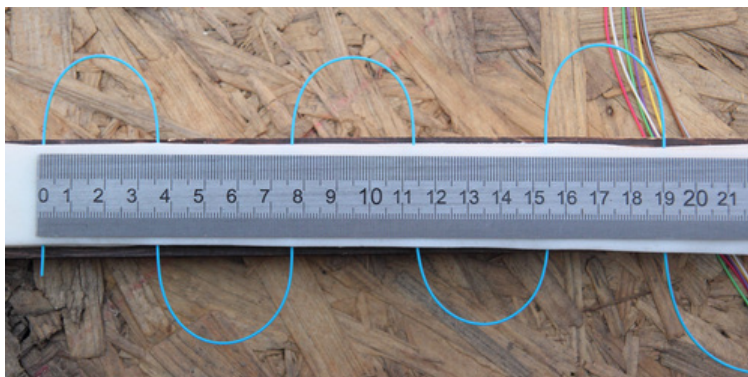

Figure 3. The meander experimental design – a single fibre is used for measurement in 6 positions. Initiation is from the left and the detonation wave sends a light pulse every time it comes into contact with the fibre

Experiment 1

A standard detonating cord (Startline 12, 12 g of PETN per m length, Explosia, Czech Republic) was used for Experiment 1. The light signal from eight glass fibres was recorded with the OPTIMEX device (handheld version). The fibres were placed directly into the PETN core of the detonation cord and initiated with a standard electric blasting cup, as shown in Figure 4.



Figure 4. The detonating cord with 8 glass fibres inserted into the PETN core as used in Experiment 1

Experiment 2

An experimental emulsion explosive (IEM, University of Pardubice, CZ) was

used for Experiment 2. In this experiment, light signals from four glass fibres were coupled together using a standard optical two-way splitter and detected with a single Tektronix optical probe. Two types of the latter were used, differing only in the operational wavelength range (6701B 500-950 nm and 6703B 1100-1700 nm). The emulsion explosive was initiated with a booster (20 g of Semtex 1A) and a standard electric blasting cup.

Experiment 3

A charge of Semtex 1A (243 g, 60 mm in diameter, density 1.43 g/cm³, Explosia, CZ) was used in Experiment 3. The front of the charge was photographed by a high speed camera to document the translucency of the material. A photograph of the charge arrangement is shown in Figure 5.

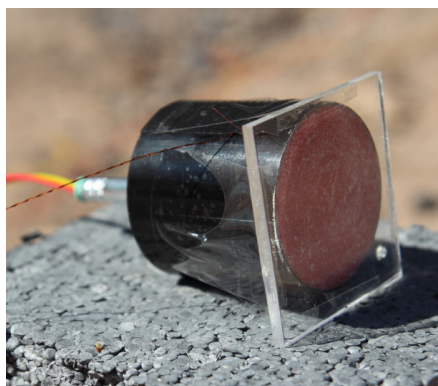

Figure 5. The charge arrangement for Experiment 3

Experiment 4

VOD of a standard detonating cord (Startline 12, 12 g of PETN per m length, Explosia, CZ) was measured in Experiment 4. Twelve independent glass fibres were used and the optical signal was recorded with OPTIMEX, Scientific table-top version.

4 Results and Discussion

Signal processing and evaluation

The assumption that the front of a detonation wave would generate a single and sharp light pulse as it reached the probe proved to be wrong. These isolated sharp light pulses are produced only in some cases, for example from a detonation

cord or from other high explosives with close to ideal behaviour. The signals from non-ideal explosives (*e.g.* PBX, or emulsion explosives) can be much more complicated with multiple peaks or a raised baseline (see results of Experiments 1 and 2). Evaluation of such non-ideal results is a bit more complicated and difficult to automate.

Some devices for VOD measurement have an adjustable threshold for evaluation of the signals obtained. Once the signal reaches the threshold value, the time is recorded and the velocity is subsequently calculated. Our experiments showed that this approach may also fail. The reason for this is that the signal from a particular probe may fall under the threshold when setting it to a level high enough to be safely above the noise level. This is more often seen in the cases of non-ideal explosives and presents a rather serious problem when multiplexing a number of probes with optical splitters. The resulting signal may then become practically unmanageable. An algorithm for the smart evaluation of VOD from more complicated signals was patented by the authors of this contribution [15].

Many explosives are also more or less translucent, which complicates the signal processing and evaluation. A typical example of such a translucent explosive is Semtex 1A (Explosia, Czech Republic) – a plastic explosive based on PETN (see Experiment 3). The light from the detonation zone is acquired by the optical probe before the wave reaches the probe. A gradual increase in light intensity is seen before the sharp rise at the time when the wave passes the probe.

A principal approach for the evaluation of the signals obtained is the final remark related to signal processing. When using two probes, one serves as the start and the other as the stop for the determination of the time between the two. From the known distance between the probes the VOD may be determined. Increasing the number of probes results in an increased number of measured intervals. Using the same methodology, as in the case with two probes, this results in a number of VODs for subsequent intervals. The resulting VODs are then statistically evaluated. An alternative approach of using the whole dependency of the position in the charge *vs.* time is considered to be easier to correctly evaluate. Outlying points can be easily evaluated and the detonation velocity is determined from the slope, in the case of a stable detonation, or the tangent in the case of measurement in a transition region (see the results of Experiment 4).

Experiment 1

The signals recorded with OPTIMEX from Experiment 1 are plotted in Figure 6. The second and all following signals are plotted with *y* offset to show the baselines of all records. The PETN inside the detonating cord is an almost ideal explosive and it is further encased in a relatively stiff and non-transparent polymer outer

jacket. This results in the appearance of just one strong peak per channel. This is an ideal case for VOD measurement and evaluation.

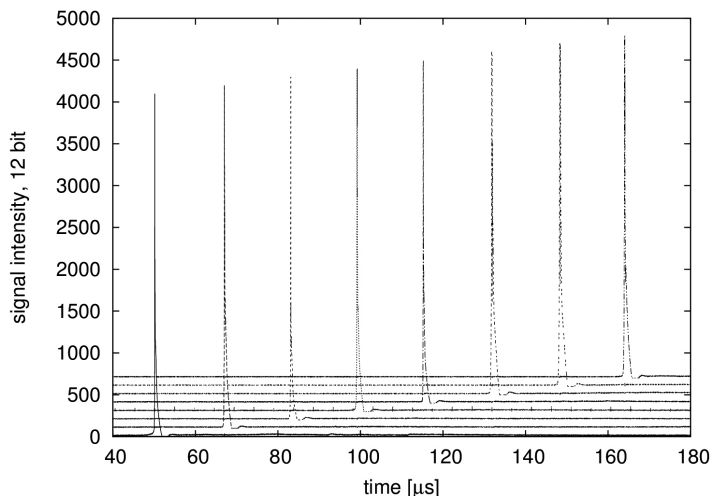

Figure 6. The recorded signal intensities from Experiment 1. The records are displaced upwards to reveal the baseline of each record

Experiment 2

This experiment represents an example of a not-so-ideal case compared to Experiment 1. Two problems appeared and were related to the charge type and the signal multiplexing. Firstly, an emulsion explosive, representing a typical non-ideal explosive, was used. Furthermore it was loaded into a transparent plastic sleeve. This resulted in eight peaks being acquired by four probes. This would not be a significant problem if the four probes were connected to four separate channels. Multiplexing of the signal by an optical coupler however combined all eight peaks together (Figure 7) and made the evaluation nearly impossible. It is difficult to determine which peak is related to which probe. This problem was also observed when using the “meander” technique with transparent confinement. The results from experiments such as this one led us to conclude that multiplexing with optical splitters is possible but needs to be used with great care. For the development of the OPTIMEX device we therefore decided to use only individual channels.

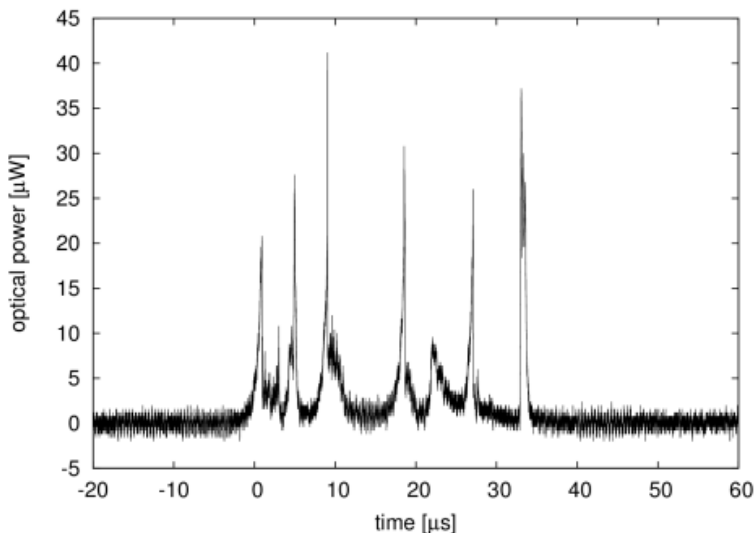

Figure 7. The recorded optical power from Experiment 2. The signals from four probes were added with an optical splitter

Experiment 3

This set of experiments was aimed at understanding the shape of the light pulse up until the probe is hit by the detonation wave. The optical probes in these experiments were placed perpendicular to the charge front and hence facing the incoming detonation wave. An ultrahigh speed framing camera was used as an independent method for obtaining information about the explosive's translucency.

Photographs of a charge front, obtained with the high speed camera UHSi 12/24 are shown in Figure 8. Frame 0 was taken for calibration, with exposure 1.2 ms. The consecutive frames show the detonation wave approaching the charge front and later emerging from the charge. The first light can be detected in frame 2 or 3, however the detonation front only really reaches the surface of the charge in frames 8 and 9. The difference between the frames is almost 600 ns. An average intensity of the central part of the charge (circle of radius 10 px) of consecutive frames can be plotted as a function of time (Figure 9). The gradual increase of the light intensity of the central region of photographed charge corresponds to the gradual increase in light intensity measured by the OPTIMEX system (Figure 9) for the same type of explosive.

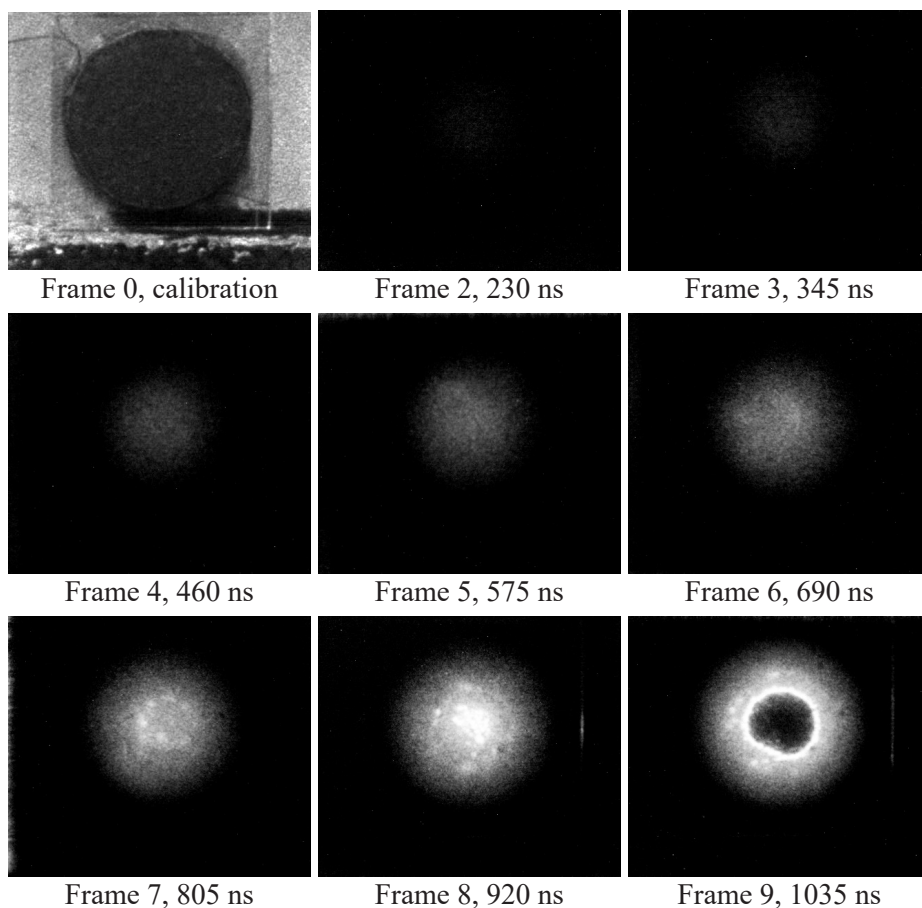

Figure 8. High speed camera photographs of the front of the Semtex 1A charge. This explosive is translucent, the traces of light can be seen from frame 3, but the front of the detonation reached the front of the charge in frame 8, 575 ns later

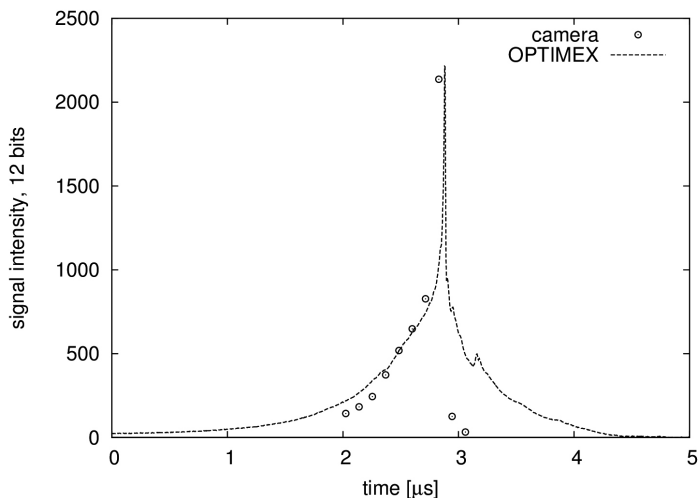

Figure 9. The translucency of explosives. The light propagates through the charge before the detonation front. Points are average values of the light intensity from the central part of the shots in Figure 8, the dashed line corresponds to the signal intensity from the glass fibre, recorded with OPTIMEX, for the same explosive (Semtex 1A)

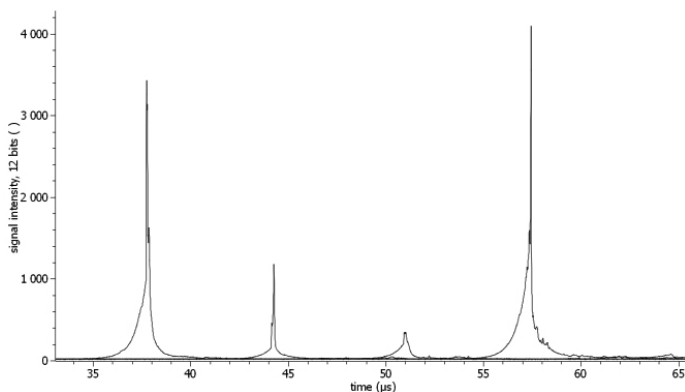

Figure 10. Light pulses from four probes inserted into the same explosive demonstrating the unpredictable maximal intensity level

The results obtained by the OPTIMEX system and confirmed by high speed imaging show significant light intensity was acquired before the detonation wave reached the optical probe. The overall shape of the peaks from multiple probes is usually similar, however differing significantly in maximum intensity

(Figure 10). Considering the same attenuation of all channels, the same length of the fibres and the same quality of the connectors, this issue would most likely be caused by the unreproducible quality of the fibre tip, which is simply cut with scissors, or, less likely, by the oscillating light intensity in the detonation zone. The best way of manually evaluating the detonation front time is by selecting a “characteristic point” independent of the overall signal intensity. Such a point can easily be identified by the abrupt change of slope of the light intensity as shown in Figure 11. In the case of the automated evaluation algorithm, consideration of the varying signal intensity must be used [15].

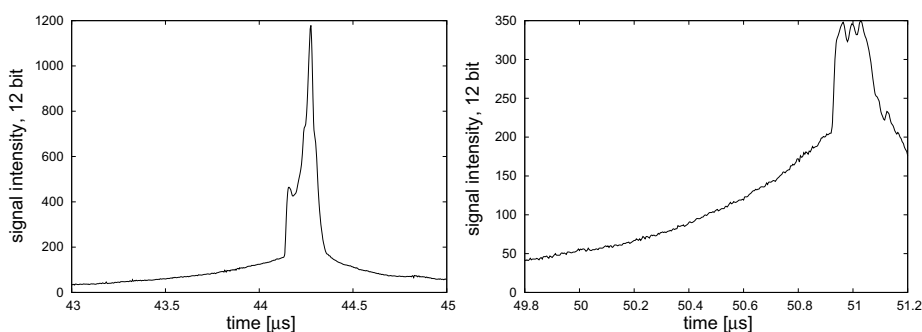

Figure 11. Second (left) and third (right) signal curves from Figure 9. The characteristic points for the correct time reading (abrupt change of slope) are clearly visible after magnification

Experiment 4

The last round of experiments was aimed at testing the distributed clock signal, enabling multiple digital boards of the OPTIMEX device to maintain synchronized time. The twelve probes also enabled us to compare the piecewise methodology of VOD evaluation with the VOD obtained from the slope of the distance vs. time plot.

The resulting record can be seen in Figure 12 – twelve clean peaks from twelve probes. The probe positions (l), peak times (t), sequential differences (dl , dt) and the corresponding VOD are summarized in the Table 1. The average detonation velocity D was 7204 m/s, with standard deviation $STD = 335$ m/s. When calculating VOD from the slope of $l(t)$ dependency (Figure 13), the value was 7198 m/s with a very high determination coefficient, $R^2 = 0.99995$. The determination of VOD from the slope takes into account all of the measured points at once, which is the main benefit of this approach. The method for determining VOD from the slope is fast, straightforward and should be preferred in all cases, when data from many probes are available.

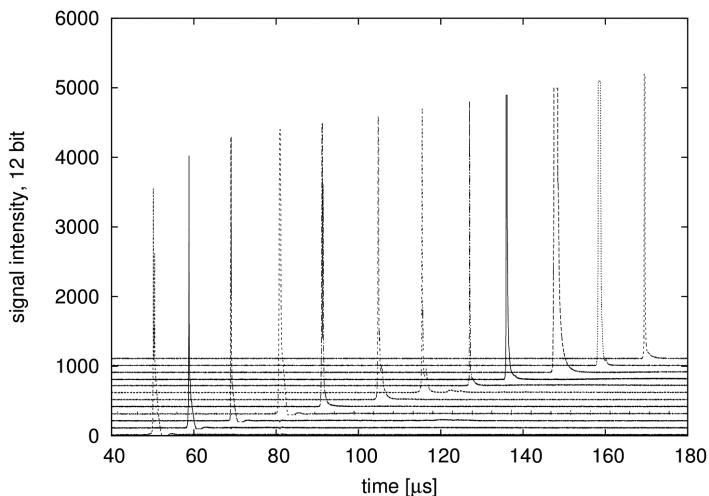

Figure 12. The recorded signal intensities from Experiment 4. The records are displaced upwards to reveal the baseline of each record

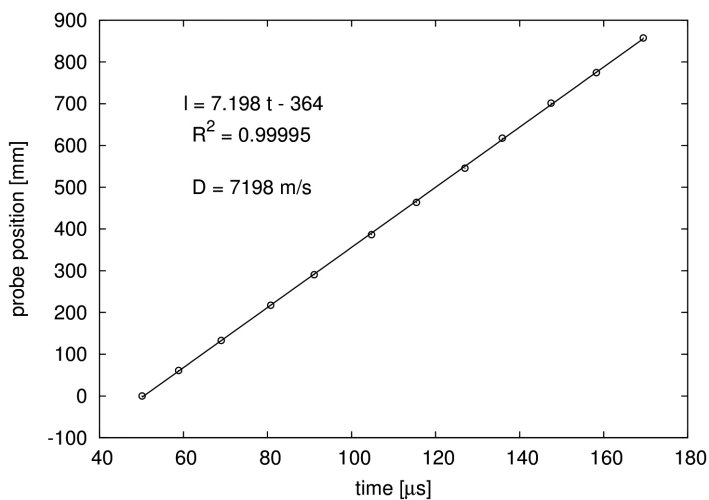

Figure 13. Determination of the detonation velocity from the slope of a plot of the probes' positions vs. peak times for Experiment 4

Table 1. Position of probes (l), peak times (t), differences (d/l and dt) and the corresponding detonation velocities (D) for Experiment 4

l [mm]	t [μ s]	d/l [mm]	dt [μ s]	D [m/s]	
0	50.156	---	---	---	
61	58.848	61	8.692	7018	
133	68.976	72	10.128	7109	
217	80.768	84.5	11.792	7166	
290.5	91.100	73	10.332	7065	
386.5	104.75	96	13.652	7032	
463.5	115.43	77	10.680	7210	$D = 7204$ m/s
545.5	126.97	82	11.536	7108	STD = 335 m/s
617.5	135.87	72	8.904	8086	
701.5	147.47	84	11.600	7241	
774.5	158.25	73	10.776	6774	
857.5	169.41	83	11.164	7435	

5 Conclusions

Both versions of the OPTIMEX devices (handheld and table-top) have been proved to work and to correctly measure VOD. Individual probes connected with individual signal data acquisition of the measured signal should be preferred to the use of splitters or other ways of coupling the signals from individual probes. The translucency of explosives could present a challenge. This problem can be solved by evaluating the peak times correctly by selecting a characteristic point on the intensity curve – the point at which there is a sharp increase in measured signal. Simple use of a constant threshold level is not recommended. The determination of VOD from the slope of the $l(t)$ dependency should be preferred in cases where many probes are used.

Acknowledgements

The work presented in this paper is the result of collaboration of University of Pardubice, Brno University of Technology, OZM Research Ltd. and Foton Ltd., supported by the Technology Agency of the Czech Republic under Project No. TA02010923. The measurements were partially performed in laboratories of SIX Research Centre, supported in frame of National Sustainability Program under grant LO1401.

References

- [1] Chapman, D. L. On the Rate of Explosion in Gases. *Philos. Mag.* **1899**, 47: 90-104.
- [2] Jouguet, E. On the Propagation of Chemical Reactions in Gases. *J. de Mathématique Pures et Appliquées* **1905-6**, 1: 347-425 (1905); 2: 5-85 (1906).
- [3] Sućeska, M. *Test Method for Explosives*. Springer-Verlag, New York, USA **1995**, pp. 93-118; ISBN 9781461269045.
- [4] Tete, A. D.; Desmukh, A. Y.; Yerounde, R. R. Velocity of Detonation (VOD) Measurement Techniques – Practical Approach. *Int. J. Eng. Technol.* **2013**, 2(3): 259-265.
- [5] Blackburn, J. H.; Seely, L.B. Detonation Light in Granular Explosives. *Trans. Faraday Soc.* **1965**, 61: 537-545.
- [6] Lu, P.; Naiman, E.; Voreck, W. E. Applications of Fiber Optics to Detonation Events. *8th Symp. (Int.) Detonation*, Albuquerque, NM, USA, **1985**, 460-467.
- [7] Mendes, R.; Ribeiro, J. B.; Plaksin, I.; Campos, J. Detonation Wave Characterization of Aluminized and Non-aluminized Emulsion Explosives. *37th Int. Conf. ICT on Energetic Materials*, Karlsruhe, Germany **2006**, 15/1-15/11.
- [8] Mendes, R.; Ribeiro, J. B.; Plaksin, I.; Campos, J.; Farinha, R. Non Monotonic Detonation Velocity and Pressure Behavior of Emulsion Explosive. *New Trends Res. Energ. Mater., Proc. Semin., 13th*, Pardubice, Czech Republic **2010**, 221-228.
- [9] Mendes, R.; Ribeiro, J. B.; Plaksin, I.; Campos, J. Non Ideal Detonation of Emulsion Explosives Mixed with Metal Particles. *AIP Conf. Proc.*, Chicago, Illinois, USA **2012**, 1426: 267-270.
- [10] Schulz, D. L. Fiber Optic Probe to Measure Downhole Detonation Velocities of Explosive Columns. *Surface Mine Blasting, Proceedings: Bureau of Mines Technology Transfer Seminar*, Chicago, Illinois, USA **1978**, 103-105.
- [11] Cui, Z.; Li, G. Study of Optical Fibers on Measuring Burning and Detonation Velocity of Mg/PEFE, PETN Film and Explosive Circuit. In: *Theory and Practise of Energetic Materials*. Vol. V, Guilin, China **2003**, 553-558.
- [12] Presles, H. N.; Vidal, P.; Khasainov, B. Experimental Study of the Detonation of Technical Grade Ammonium Nitrate. *C. R. Mecanique* **2009**, 337: 755-760.
- [13] Prinse, W.; van Esveld, R.; Ostdam, R.; van Rooijen, M.; Bouma, R. Fibre-optical Technique for Measuring Various Properties of Shock Waves. *23rd Int. Congress on High-Speed Photography and Photonics*, Moscow, Russia **1998**, 246-251.
- [14] Chan, E.M.; Lee, V.; Mickan, S. P.; Davies, P. J. Low-cost Opto-electronic Devices to Measure Velocity of Detonation. *Proc. SPIE*, 5649, **2005**, 586-594.
- [15] Krupka, M.; Moravec, J.; Pachmáň, J.; Šelešovský, J.; Maršálek, R.; Šebesta, V.; Prokeš A. Method of Measurement and Evaluation of the Time History of Sequential Optical Signals Generated by Explosion. (in Czech) Patent CZ 305407, **2015**.