

SCIENTIFIC PAPERS
OF THE UNIVERSITY OF PARDUBICE
Series B
The Jan Perner Transport Faculty
9 (2003)

**UTILIZATION OF INDUCTION-MACHINE MATHEMATICAL MODEL
FOR MEASURING TECHNIQUE**

Vladimír SCHEJBAL ¹⁾, Jaroslav NOVÁK ²⁾, Stanislav GREGORA ¹⁾

¹⁾ Department of Electrical, Electronic and Safety Engineering, Jan Perner Transport Faculty,
University of Pardubice

²⁾ Department of Instrumentation and Control Engineering, Faculty of Mechanical Engineering,
Czech Technical University in Prague

1. Introduction

Measurements are a very important part of research and development of any electrical equipment. The measuring system for testing of especially AC electric drives has been completed at the Department of Electrical, Electronic and Safety Engineering of Jan Perner Transport Faculty of University of Pardubice [1]. Measurements are performed both for steady and transient states. The real-time processing of electric and non-electric quantities is used.

The measuring system consists of two parts. The first part contains a system of non-electric quantities sensors for direct measurements, where evaluation is performed by use of a storage oscilloscope or a PC with an additional measuring card.

The other part is a microprocessor measurement and computing unit, which measures electric and non-electric quantities. The unit then performs real-time computations of the other drive quantities. The measured and computed quantities loaded into the PC.

2. Microprocessor unit

The microprocessor unit consists of three blocks which can be seen in **Fig. 1** shown at the bottom of the figure. The central block is formed by the board TPP-1. This board is produced industrially in the Czech Republic [2]. Its purpose is to control and monitor the electric drive. It is equipped with the microprocessor TMS 320F240, auxiliary circuits of processor, memories, communication links and programmable logic array, which control the board functions. The board is equipped with 10 analog inputs, which are connected to two A/D converters with 6.6 μs conversion time. Moreover, logic inputs and outputs are available including fast inputs for connecting a pulse speed sensor. The board contains firmware for user program entering. The serial link connects the board with the PC to which the measured and computed quantities are fed. The PC can then process further these data.

The power supply part (the second block of device) is supplied with a 230V 50 Hz power network. DC/DC converters deliver the stabilized voltages for the DSP board and for sensors, as well as the 2.5V voltage for a middle point for measurements of double-polarity voltages, implementing a single-polarity A/D converter.

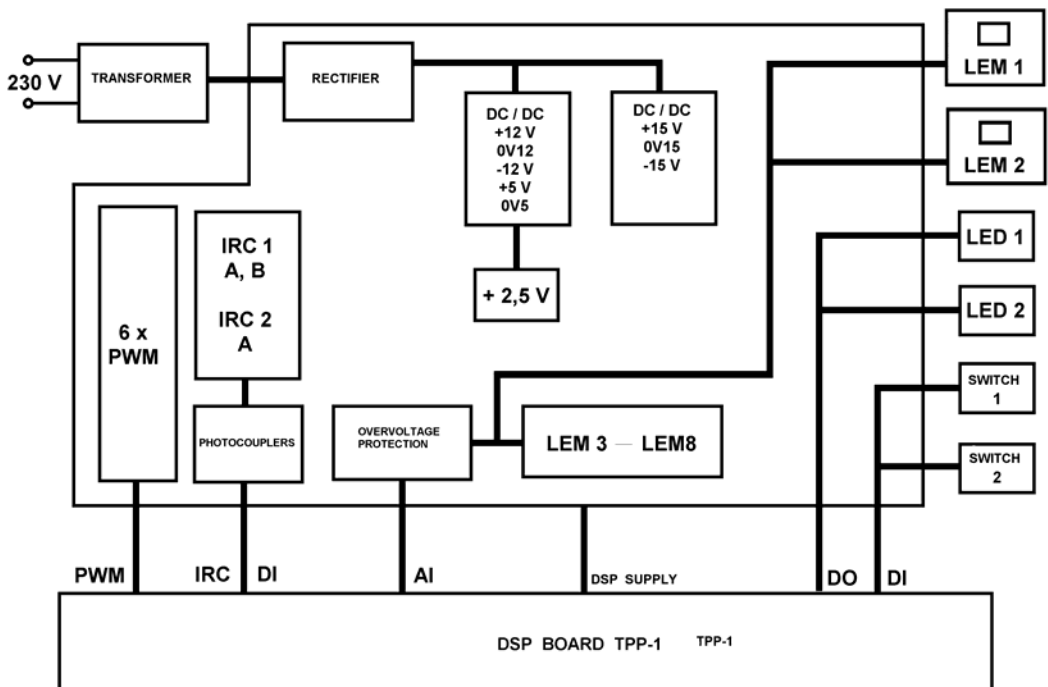

Fig. 1 Microprocessor unit block diagram

The third block is formed by an interface card used for matching of the measured data. It contains circuits ensuring optical separation and the signal matching of two motor speed sensors. One sensor is equipped with the direction of rotation resolution, the other

not. The interface card is capable of connecting eight analog double-polarity signals. Two of them are connected to current sensors LEM 1, LEM2 in *fig. 1*. The analog inputs d LEM3 to LEM8 can be used for connecting another current or voltage sensors with Hall probes or for connecting separated analog signals for linear optocouplers or, finally, for connecting sensors of non-electric quantities with analog outputs.

There exist several measuring programs and as every modification is developed according to the respective measurement task, creation of other modifications is assumed. Individual programs can be divided into three groups. The first group contains the programs for measurements and for the record of variables, directly scanned by sensors. The second program group is deals with the evaluation of power and energy balances of drives. These are programs directed at the computation of power and efficiency using variables, both electric and non - electric. The real-time computations are performed using DSP and responses are shown and recorded with a PC. Another more complicated operation, such as FFT, can be performed with the use of PC non-real time processing. The third program group is oriented towards the determination of internal variables (such as magnetic flux and internal electromagnetic torque) for AC electric machines using real-time computations of mathematical models. These methods, have been mostly used for our computation of the current model for an asynchronous machine [4].

Here, a complex analysis of the asynchronous machine is to be performed, which includes the determination of particular machine properties, the performance analyses of drives with given loads or debugging of control units, the responses of electric, mechanic and magnetic quantities, which are mutually interconnected at.

Mathematical models can be used especially for the determination of torque. Investigation of instantaneous torque response in electric drives a is relatively demanding technical task. Torque sensors from various producers, which are based on various principles employing the tensometer bridges, are available on the market. Using these sensors, high quality torque information can be obtained. However, these sensors are not often sufficiently resistant against overloading. Moreover, their the price is rather high. At the same time, the sensors can be used under laboratory conditions only and usually not in already industrial drives.

The torque, magnetic flux current and voltage waveforms are usually obtaint through computation in transformed coordinate systems. The mathematical model computations of induction machines are nowadays realized by control processors designed for the control electronic converters with higher control structures. The computation results satisfy the accuracy requirements for control feedback data or for gaining rough impression about drive state. However, they are not suitable for the accurate drive analyses. The reasons for a low accuracy of these values obtained by computation are the relatively low sampling frequency and the mathematical model simplifications. The converter control processor, apart from the mathematical model

calculations, should also realize the whole control structure and needn't therefore work with high accuracy.

During the creation of code for asynchronous machine analyses, the best effort has been given to the utilization of maximum processor performance for increasing the accuracy of the mathematical model. The aim was implement the results obtained from the model for more accurate measurements of drive systems. The higher accuracies have been especially reached through the use of short computation periods and through respecting non-linear behavior of the machine magnetic circuit and the losses in the magnetic circuit. This causes an increase in the inaccuracy of the torque computation. Therefore, the main aim and criterion are the computation torque values, to the determination of which will be paid by the highest attention.

3. The basic structure for mathematical model of induction machines

The idea of a asynchronous machine mathematical model, realized by measuring equipment, is based on the calculating of standard mathematical model for a two-phase system and on the following increase inaccuracy of computation. Due to simpler calculation of transformation between real three-phase system, which is used for measurement of machine variables, and the two-phase system, which is used for calculation, the stable α, β system has been used for measuring equipment.

Using the voltage standing α, β two-phase system the voltage equations for machine stator circuit can be written as follows:

$$\hat{U}_1 = R_1 \hat{I}_1 + \frac{d\hat{\Psi}_1}{dt} + j\omega_k \hat{\Psi}_1 \quad (1)$$

\hat{U}_1 is the space vector of stator terminal voltage, \hat{I}_1 is the space vector of stator current, ω_k is the angular velocity of the coordinate system. The first term on the right side of equation (1) is the ohmic voltage drop of stator winding, $\hat{\Psi}_1$ is the stator linkage, the second term on the right side of equation (1) is the voltage drop of stator winding due to the magnitude change of stator linkage and the last term on the equation right side is the voltage drop due to position change, i.e. due to speed of the rotating magnetic field relativ to the stator winding.

The analogue equation is valid for the rotor circuit, where the subscript 2 denotes the rotor variables:

$$\hat{U}_2 = R_2 \hat{I}_2 + \frac{d\hat{\Psi}_2}{dt} + j(\omega_k - p_p \omega_m) \hat{\Psi}_2 \quad (2)$$

Here p_p is the number of machine pole pairs and ω_m is rotor mechanical angular velocity. The left-hand side of equation (2) equals zero for a squirrel-cage motors.

For the stator and rotor linkages, the following equations are valid:

$$\hat{\Psi}_1 = L_1 \hat{I}_1 + L_h \hat{I}_2 \quad (3)$$

$$\hat{\Psi}_2 = L_2 \hat{I}_2 + L_h \hat{I}_1 \quad (4)$$

where L_1 and L_2 are the self-inductances of the stator and rotor circuits and L_h is mutual inductance between stator and rotor. The machine parameters are the same as the parameters in the induction motor equivalent diagram. The inductances are: $L_1 = L_h + L_{1\sigma}$; $L_2 = L_h + L_{2\sigma}$.

For the standing coordinate system α , β , which is used in the measuring equipment, $\omega_k = 0$. Then in this coordinate system, the internal electromagnetic torque is given by:

$$M = \frac{3}{2} p_p (\Psi_{1\alpha} i_{1\beta} - \Psi_{1\beta} i_{1\alpha}) = \frac{3}{2} p_p \frac{L_h}{L_2} (\Psi_{2\alpha} i_{1\beta} - \Psi_{2\beta} i_{1\alpha}) \quad (5)$$

From equation (5) follows that the internal electromagnetic torque can be calculated using the components of the stator current and of the stator or rotor linkages.

The equations (1) to (4) show that the magnetic flux Ψ_2 can be computed using two methods: either from the stator currents and voltages (so-called voltage model) or from the stator currents and rotor mechanical speed (so-called current model).

The starting point for creating the program is the current model. The choice of the current model is mostly given by the fact that the voltage model is not accurate enough due at low induced voltage at low and zero revolutions and, moreover, the voltage model creates signal distortion due to sensor time constants during voltage measurement. That would be especially pronounced with asynchronous machines fed from semiconductor converters, when high gradients in voltage increase and decrease occur. When the voltage models are used for converters produced industrially this problem is removed, as the converter control processor determines the instantaneous values of stator voltages using the measured values of the inverter DC input and the known state of switches in the converter.

The real-time computations of rotor magnetic flux components $\Psi_{2\alpha}$, $\Psi_{2\beta}$ are based on the equations derived from voltage equation for rotor circuit:

$$\frac{d\Psi_{2\alpha}}{dt} = p_p \omega_m \Psi_{2\beta} - \frac{R_2}{L_2} \Psi_{2\alpha} + \frac{L_h R_2}{L_2} i_{1\alpha} \quad (6)$$

$$\frac{d\Psi_{2\beta}}{dt} = -p_p \omega_m \Psi_{2\alpha} - \frac{R_2}{L_2} \Psi_{2\beta} + \frac{L_h R_2}{L_2} i_{1\beta} \quad (7)$$

4. Increase in the mathematical model accuracy

The above equations are based on simplified assumptions. The computation accuracy is then affected mostly by neglecting magnetic circuit saturation as well as iron losses and possibly also additional losses.

The computation accuracy of magnetic flux components $\Psi_{2\alpha}$, $\Psi_{2\beta}$, which are the input values for the computation of the internal torque according to equation (5), depends especially on the accuracy of the resistance R_2 referred to the stator and on the value L_h . Moreover, it depends on the sampling period. Considering the used microprocessor, the whole code organization and the clear arrangement of results, the computation period of 100 μ s for equations (6) and (7) has been chosen.

The rotor resistance value R_2 can be determined by the short-circuit measurements and the main inductance value by the open-circuit measurements. The R_2 value can be changes during long-time machine load due to temperature. Some mathematical models, especially if the long-time high-load drive is analyzed, consider this dependence through the use computation of simplified thermal model.

The computation accuracy is considerably affected by the change of L_h due to magnetic saturation. That parameter change has been considered even in the code. The code considers the saturation effect and adapts L_h values according to magnetic flux Ψ_2 . The table of L_h for individual fluxes Ψ_2 has been computed using the results of open-circuit motor measurements. Neglecting iron losses and the effect of small voltage drop on the stator impedance the following equations are valid:

$$L_h = \frac{\sqrt{3}U_1^2}{Q\omega_1} \quad (8)$$

$$\Psi_2 = L_h I_1 \quad (9)$$

where ω_1 is the angular frequency of stator voltage and the values U_1 and Q (reactive power) have been determined by open-circuit measurements. The calculated dependence of $L_h = f(\Psi_2)$ has been piecewise by linearized and its behavior is considered by varying the value of R_2/L_2 term in equations (6) and (7). The following description and figures are related to the motor which has been used for debugging. It was an induction motor 4.4 kW, 3x380 V, 9.6A, 1370 rpm.

The instantaneous value response for internal electromagnetic torque, determined by real-time computation using the current model according to equation (5), is shown in Fig. 2. The most expressed component is the sixth harmonic as the motor has been fed by a semiconductor frequency converter.

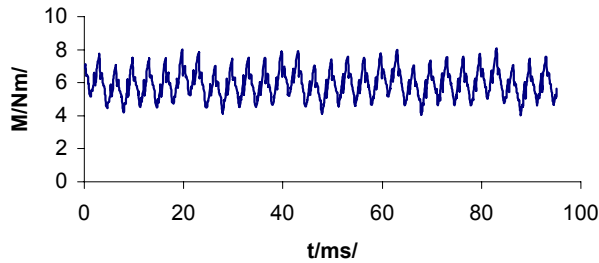

Fig. 2 Instantaneous response of internal electromagnetic torque of induction motor

The difference between the internal electromagnetic torque calculated according to (5) and the shaft torque value is caused mostly by neglecting the magnetic circuit losses and the additional losses. The individual type loss effects on the accuracy of mechanical torque calculation can be observed in **tab. 1**.

Loss type	Part of total losses [%]	These losses of the particular type are/are not considered by equation (5)
Joule's losses – stator	42,2	Considered
Joule's losses – rotor	22,5	Considered
Iron losses of stator magnetic circuit	15,3	Not considered
Mechanical and ventilation losses	11,1	Not considered
Additional losses	8,9	Not considered

Tab. 1 Loss distribution for induction motor

Tab. 1 from [5] is valid for a motor with the rated power of 14 kW, the total losses being 11,37 % of the rated power when under nominal load. **Tab. 1** shows, that most of the losses occur in the windings, which is considered by mathematical model. As to losses neglected in the mathematical model, iron magnetic circuit losses, mechanical and ventilation losses are involved. However, the table is valid for sinusoidal motor feeding

only. For semiconductor converter feeding, additional losses caused by higher harmonics of voltages and currents occur. Their effect is of little important.

Considerations in the previous paragraph are relate to the torque mean value. The waveforms of the instantaneous values of the torque on the shaft differ from internal electromagnetic torque waveforms due to inertial rotating mass effects. The internal electromagnetic torque always indicates fluctuations causes by time and spatial harmonics. These fluctuations are then filtered thanks to the moment of inertia. Hence the fluctuations of the drive torque on the shaft of the driven equipment are less pronounced.

The presented study shows, that the correction of iron losses in the real – time mathematical model can bring an increase in its accuracy. The instantaneous value computation of iron losses is performed by material-magnetic calculations. The computation of magnetic circuit properties is done by numerical methods, the real-time computation being not solvable. Therefore, the torque mean value is corrected considering iron losses in the code of measuring equipment. The torque instantaneous values represent internal electromagnetic torque.

The idea of the torque mean value corrections is as follows. The magnetic circuit iron losses are involved into losses, that are independent of the motor load and that do not change substantially with motor load. The mean value of iron losses is given by the following equation:

$$\Delta P_{Fe} = k_p m B^2 f_1^{1,3} \quad (10)$$

where k_p is a material constant, m is mass, B is magnetic flux density, and f is the frequency of stator voltage. Considering the fact that the relevant magnetic flux is proportional to magnetic flux density, the dependence of ΔP_{Fe} on the magnetic flux is computed using input power measurement for ideal open-circuit state, mechanical losses being covered by another drive unit.

Iron magnetic circuit losses cause that the value of internal torque is decreased due to ΔP_{Fe} . That can increase the computation accuracy of mechanical torque of shaft. This correction torque can be written by neglecting mechanical and additional losses as follows:

$$M = \frac{P_m + \Delta P_{Fe}}{\omega_1} \Rightarrow \Delta M_{Fe} = \frac{\Delta P_{Fe}}{\omega_1} = \frac{k_p m B^2 f_1^{1,3}}{2\pi f_1} = \frac{k_p m (k_p \Phi)^2 f_1^{1,3}}{2\pi f_1} \quad (11)$$

where P_m is mechanical motor output, ΔM_{Fe} is correction torque, k_ϕ is the proportional constant between magnetic flux density and magnetic flux, and Φ is related magnetic flux. The correction torque depends on magnetic flux and frequency. For real – time computation the dependence on frequency is relatively complicated. Therefore during system debugging, the possibility of neglecting frequency effects has been investigated considering iron loss dependences just as the first power of frequency. The measurement results show that the utilization of this assumption does not cause

noticeable decrease in computation accuracy. The computed correction torque can be expressed as:

$$M_m = M - \frac{k_p m (k_\phi \Phi)^2}{2\pi} \quad (12)$$

5. Output variables of mathematical model and program structure

The inputs of the described code for real-time computation of the mathematical model of an asynchronous machine are the motor speed scanned by an incremental sensor with 1024 pulses per revolution with direction resolution and two phase currents of the machine stator. These values as well as all values computed at individual states of the used algorithm are available and visible using PC. They involve, the stator current components of rectangular coordinates α , β , related rotor magnetic flux components, stator current phasor modules, rotor magnetic flux values, instantaneous values of internal electromagnetic torque, mean values of internal electromagnetic torque, mechanical torque values computed with correction, stator current magnetized components, stator current torque components and mechanical outputs. All described variables can be shown as filtered or non-filtered.

The torque component of stator current i_{1q} is computed using coordinates d , q according to equation

$$i_{1q} = \frac{2M}{3p_p \Psi_2} \quad (13)$$

The magnetic component of stator current i_{1d} is computed according to equation:

$$i_{1d} = \frac{\Psi_2}{L_h} \quad (14)$$

At states above, L_h is not constant, but varies according to the position of the operating point in the machine magnetic characteristics. The motor magnetic non-linearity is compensated in the calculation of components $\Psi_{2\alpha}$, $\Psi_{2\beta}$. The inductance L_h is adapted according to dependence measured in open-circuit state. The adaptation is done according to piecewise-linearized in three steps.

The whole program concept is as follows. After initialization, the event manager processor module generates with a 100 μ s period and the A/D conversion is started using two built-in converters in parallel. The sensor signals of two machine phase currents are fed to the inputs of the converters. The interrupt is generated after conversion and interrupt's whose service program performs mathematical model computations. After every interrupt, the transformation of two stator phase current into α , β coordinates and equations (6) and (7) are computed. That enables to determine the magnetic flux components. The instantaneous value of internal electromagnetic torque is determined according to equation (5) and the filtering of the mentioned quantities is performed. By

the time necessary for the computation of equations (6) and (7), the computation on accuracy is influenced substantially. It is necessary to keep this time as short as possible. The evaluation of the speed based on the pulse number sent by incremental sensor is done during each of the fifty interruptions, i.e. ones per 5 ms.

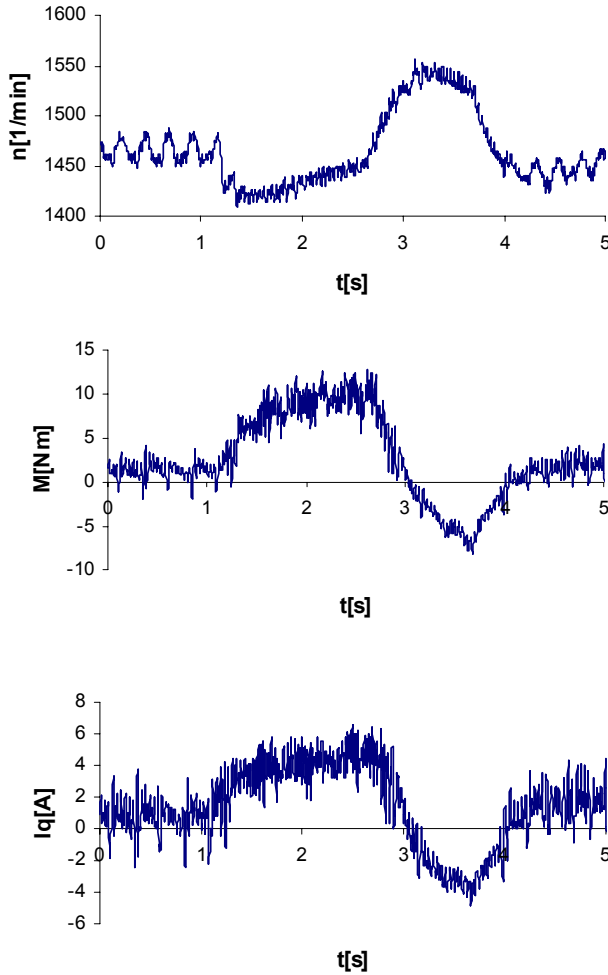

Fig. 3 Mathematical model utilization at dynamic modes – drive with feedback control and with optimizing magnetic flux

The interruptions from A/D converters are arranged into groups of ten. During any interruptions of these ten, the computation of some other quantity is performed. Some of

the computations are time consuming (such as the computations of current module and magnetic flux using Pythagorean theorem) and their performing during every 100 μs period is not necessary. However, the computation rate does not affect the accuracy. So the α , β component values of stator currents and rotor magnetic fluxes are recalculated every 100 μs , the other variable values are recomputed at 10 times longer intervals, once in 1 ms.

The communication with PC using RS 232 link is accomplished on the base level of the whole program.

A detailed verification of proper function of the measuring equipment was performed with the aid of an application program for real-time analyses of induction motors. A few examples are shown in **Fig. 3**.

6. Conclusions

The microprocessor unit is used for research and education and no changes in its hardware part are supposed. Every future development will be connected with the programming of subsequent program blocks. The future aim of the described solution is to improve the present real-time models of asynchronous machine through adding several blocks, such as the block for real-time harmonics computation etc.

Lektoroval: Doc.Ing. Stanislav Bartoš, CSc.

Předloženo: 5.4.2004

References

1. NOVÁK J., GREGORA S. *Testing Equipment with Load Torque Programmable Simulation. Conference Proceedings EPE – PEMC 2000*, pp. 7-191-7-193, Košice 2000. ISBN 80-88922-24-0.
2. *TPP-1 Processor board for drive controller – user manual*. Company Uniccontrols a.s., the Czech Republic, Prague 1999
3. *TMS 320F240 DSP Controllers – Firm Texas Instruments*
4. NOVÁK J., GREGORA S., SCHEJBAL V. *Study of Methods for Induction Machine Torque Monitoring. Conference Proceedings EPE-PEMC 2002*, CD-ROM – T7-020, Dubrovnik 2002. ISBN 953-184-047-4.
5. PETROV G. N. *Electrical Machines 2*. Academia Praha. Praha 1982

Resumé

POUŽITÍ MATEMATICKÉHO MODELU INDUKČNÍHO STROJE PRO MĚŘICÍ TECHNIKU

Vladimír SCHEJBAL, Jaroslav NOVÁK, Stanislav GREGORA

Článek prezentuje návrh a možnosti měřicího zařízení, které se používá pro testování elektromechanických systémů, zejména pohonných jednotek s indukčními motory. Funkce zařízení je založená na výpočtu proudového modelu indukčního stroje a následným zvýšením přesnosti. Hlavní pozornost se věnuje nepřímému určení momentu výpočtem v reálném čase.

Summary

UTILIZATION OF INDUCTION-MACHINE MATHEMATICAL MODEL FOR MEASURING TECHNIQUE

Vladimír SCHEJBAL, Jaroslav NOVÁK, Stanislav GREGORA

The design, application and capability of a measuring equipment, used for testing electromechanical systems, especially drive units with induction motors, are presented. The equipment function is based on the computation of an induction machine current model with increased accuracy. The main attention is paid to indirect torque determination by real-time computation.

Zusammenfassung

ANWENDUNG EINES MATHEMATISCHEN MODELS EINER INDUKTIONSMASCHINE FÜR DIE MESSTECHNIK

Vladimír SCHEJBAL, Jaroslav NOVÁK, Stanislav GREGORA

Dieser Aufsatz beschreibt den Entwurf, sowie die Fähigkeiten einer Messanlage, die zur Prüfung elektromechanischer Systeme, besonders Treibeinheiten mit Induktionsmotoren, anwendbar ist. Die Funktion dieser Anlage beruht auf der sich an Berechnung eines Modells der Induktionsmaschine und auf erhöhten Mengengenauigkeit dieses Modells darauf folgende höhere Messgenauigkeit. Die Betonung wird auf die indirekte Berechnung des Momentes in Realzeit gelegt.