

SCIENTIFIC PAPERS  
OF THE UNIVERSITY OF PARDUBICE  
Series A  
Faculty of Chemical Technology  
21 (2015)

**THE EFFECT OF FEED PRETREATMENT  
ON MEMBRANE MICROFILTRATION OF  
TITANIUM DIOXIDE DISPERSIONS BY  
CERAMIC TUBULAR MEMBRANES**

Miroslav GRULICH and Petr MIKULÁŠEK<sup>1</sup>  
Institute of Environmental and Chemical Engineering,  
The University of Pardubice, CZ–532 10 Pardubice

Received December 3, 2014

*The influence of a coagulant type and operating parameters on crossflow microfiltration of aqueous dispersions of titanium dioxide has been examined. The experiments were carried out with a tubular ceramic microfiltration membrane of nominal pore size 0.1  $\mu\text{m}$  at various operating parameters. Three chosen types of organic coagulants were used for a series of crossflow microfiltration experiments: polyacrylamide (PAM), poly(diallyldimethylammonium chloride) (pDADMAC) and poly(acrylamide-co-acrylic acid) partial sodium salt (PACA). The value of steady-state permeate flux has been experimentally evaluated for the crossflow microfiltration with and without pretreatment.*

*The results of the experiments without coagulants have shown that initial flux declines rapidly, but after an initial decline, the flux is stabilised. The results also suggest that pDADMAC is a better coagulant for this system and its optimum*

---

<sup>1</sup> To whom correspondence should be addressed.

concentration is  $30 \text{ mg l}^{-1}$ . Finally, it is shown that the feed pretreated by pDADMAC has resulted in more than three-times higher permeate flux than that without any pretreatment. Moreover, there was a very positive effect of this coagulant on the particle size. Pretreatment by  $30 \text{ mg l}^{-1}$  pDADMAC has led to almost eighteen-times higher average particle size compared to the average particle size without pretreatment. The other two coagulants did not show such improvements as pDADMAC; pretreatment of the feed by PAM giving only a 10 % higher permeate flux whilst the pretreatment of the feed by PACA causing even lower permeate flux than those without any pretreatment. Thus, the individual experiments have suggested us the need for careful selection of coagulants, because of their different impact upon the permeate flux.

## Introduction

Membrane microfiltration is a pressure-driven process with a microporous membrane as the separating medium [1]. The pore sizes of microfiltration membranes range from 10 to  $0.05 \mu\text{m}$ , making the process suitable for retaining suspensions and emulsions. Microfiltration is the membrane process which most closely resembles conventional coarse filtration [2].

Basically, microfiltration can be operated in two modes: (i) dead-end and cross-flow. In dead-end arrangement, the entire feed flow transports towards the membrane perpendicularly so that the retained particles and other components are accumulated and deposited onto the membrane surface. As opposed to dead-end microfiltration, in a cross-flow operation, the feed stream moves in parallel to the membrane surface and only a portion of the feed stream passes through the membranes under the driving pressure [3]. The tangential flow generates the respective forces that tend to remove the deposited layers from the membrane surface, helping to keep the membrane relatively clean. Operational cost of the cross-flow mode is higher than that of the dead-end mode because of the energy needed to circulate the feed flow. The circulation of the dispersion around the membrane surface and the permeate removal result in the increasing concentrations of a component in the retentate and the decreasing flux [4].

When microfiltration is applied, the main problem encountered is the flux decline. This is caused by the concentration polarisation and fouling; the latter being the deposition of solutes inside the pores of the membrane or at the membrane surface. The steady state permeate flux may be as low as 2-10 % of that of pure water flux [2].

The flux decline can be reduced using two groups of special methods. The first group requires discontinuation process; namely, chemical and mechanical cleaning or backwashing. The second group of methods can be used without discontinuation (e.g., feed pretreatment, influencing the interaction phenomena

between the particles and the surface of the membrane, hydrodynamic methods) [5]. One of the suitable feed pretreatment methods can be the coagulation, when the respective coagulants can be divided into several categories: simple inorganic coagulants, prehydrolysed metal salts, organic polymers, and natural coagulants. The selection of these chemicals and flocculation aids for use in a particular plant is generally based on economic considerations along with reliability, safety, and chemical storage considerations. The best method for determining treatability, the most effective coagulants, and the required dosages are to conduct bench-scale and, in some cases, pilot tests [6].

Microfiltration is used in a wide variety of industrial applications. The most important applications of microfiltration are wastewater treatment, sterilization and clarification of all kinds of beverages and pharmaceuticals in the food and pharmaceutical industries, removing the particles during the processing of ultrapure water in the semiconductor industry [7].

In literature, we can find many studies about feed pretreatment. Erdei *et al.* and Park *et al.* [8,9] investigated coagulation and its effect on the flux decline and the removal of pollutants in wastewater treatment. The results of these studies show that coagulation has a positive effect on the flux decline and the removal of colloidal pollutants from wastewater. Erdei *et al.* [8] have also found that the results are highly dependent upon the type of coagulant. Zhu *et al.* [10] report on the membrane fouling in wastewater treatment, when the results obtained showed that coagulant dosage would have a clear influence on membrane fouling during microfiltration. Furthermore, Bhattacharya *et al.* [11] have investigated microfiltration of textile industry water with pretreatment by coagulation with ceramic membrane. Their results reveal that the optimum coagulant was a dye removal about 96 %, but with higher dosage of coagulant only about 85 %.

Zhao *et al.* and Wang *et al.* [12,13] investigated coagulation and its effect on the formation of particles and effect on the particle size. Their studies have shown that coagulation had a positive effect upon the particle size and also, on the permeate flux. Regarding the type of coagulant, its proper choice had significant effect on the structure of the particles and the particles size. In contrast, Hofs *et al.* [14] have found that coagulation might have a negative effect on the membrane fouling. In their study coagulation had a positive effect on the reversible membrane fouling, but a negative effect on the irreversible membrane fouling.

Finally, Wang *et al.* [15] studied the factors and mechanisms of fouling of the microfiltration membranes by organic polymers, which had been used for the feed pretreatment. The obtained results confirmed that the high concentrations of coagulant might cause a clogging of the membrane due to the presence of free polymer molecule. Similar conclusions were outlined by Wu *et al.* [16] ascertaining that optimum coagulant concentration reduced the risk of membrane fouling, whereas its higher concentration had already led to the membrane fouling, because of blocking of the membrane pores by the added coagulants.

## Experimental

The microfiltration experiments were carried out with an aqueous dispersion of titanium dioxide ( $\text{TiO}_2$ ; anatase form, PRECHEZA, the Czech Republic). The dispersions were prepared from powdered titanium dioxide and deionized water at a concentration of 3 wt. %  $\text{TiO}_2$ . This concentration was chosen because of a need to prepare the dispersion at higher concentration for real application. Also, this concentration was suitable because the higher level (over 10 %  $\text{TiO}_2$ ) exhibited undesirable strong non-Newtonian behaviour [17]. Furthermore, the rising content of the solid phase causes conditional static yield stress [18].

The average particle size of the dispersion was  $0.486 \mu\text{m}$ , when the respective particle size distribution curve had shown two maxima. The first one was the major peak with an average particle size of about  $0.5 \mu\text{m}$ , the second peak having an average particle size of about  $10 \mu\text{m}$ . The particle size distribution was measured by the Mastersizer instrument (model 2000 MU) and the resultant graph is illustrated in Fig. 1.

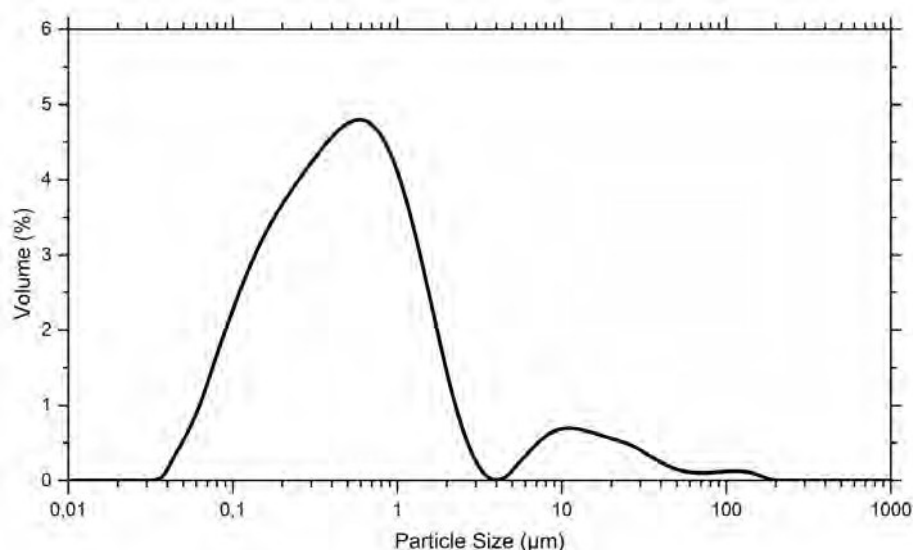

Fig. 1 Particle size distribution of the titanium dioxide dispersion used (measured by Mastersizer MU 2000)

In the separation experiments, asymmetric  $\alpha\text{-Al}_2\text{O}_3$  microfiltration membranes (TERRONIC, the Czech Republic) were used. They were configured as single cylindrical tubes, 25 cm long, 6 mm in inner, and 10 mm in outer diameter, with the active layer deposited on the internal surface of the tubular support. The basic properties of the membrane are shown in Table I.

After each experiment, the membrane was washed with demineralised water, mechanically cleaned with a special brush. Subsequently, the membrane was cleaned for 30 min with ultrasound. After cleaning of the membrane, the

reproducibility was checked by measuring the clean water flux. If a drop of pure water flow rate had been higher than 10 % compared to the original value, the membrane was excluded from further experiments.

Table I Membrane characteristics

Producer	Terronic
Material	$\alpha$ -Al <sub>2</sub> O <sub>3</sub>
Geometry	Tubular
Nominal pore diameter	0.1 $\mu$ m
Membrane area	43.35 cm <sup>2</sup>
Permeability	1 895 l m <sup>-2</sup> h <sup>-1</sup> bar <sup>-1</sup>

Microfiltration was operated in the cross-flow configuration and the corresponding experimental equipment shown in Fig. 2. The feed dispersion was pumped from storage tank (1) to the membrane module (3) by a membrane pump (2) (HYDRA-CELL PUMP) controlled by a frequency converter of speed (model VA 02B-03, TOS Kuřim, the Czech Republic). The permeate flux was measured by weight by electronic balance (4) (model KERN 573-46NM, Kern; Germany) connected *via* RS 232 serial communication port with personal computer (5). The retentate was returned to the storage tank; the permeate being also returned to the feed tank for keeping the constant feed concentration. The pressure was adjusted to the target value by regulating valve (6) and trans-membrane pressure measured by manometer (7) (model TMG 567 C3H, CRESSTO, the Czech Republic). The flow rate of the feed was determined by flowmeter (8) and temperature of feed maintained constant by the tempering system (9).

Three types of organic coagulants were used for a crossflow microfiltration experiments: (i) polyacrylamide (PAM) 50 wt % solution with average molecular weight 10,000 g mol<sup>-1</sup>, (ii) poly(diallyldimethylammonium chloride) (pDADMAC) 20 wt % solution with average molecular weight 400,000-500,000 g mol<sup>-1</sup>, and (iii) poly(acrylamide-co-acrylic acid) partial sodium salt (PACA) 80 wt % solution with average molecular weight 520,000 g mol<sup>-1</sup>. All three coagulants were purchased from Sigma-Aldrich.

During all the tests, the microfiltration process was run at a constant cross-flow velocity of 2 m s<sup>-1</sup> and at the 100 kPa pressure difference; the temperature of dispersion being 20 °C. The particle size distributions were determined by Mastersizer MU 2000, (Malvern Instruments) and by Zetasizer Nano ZS (the same manufacturer).

By employing the Mastersizer MU 2000, the particle size measurements were performed using laser diffraction and the particle size range measured from

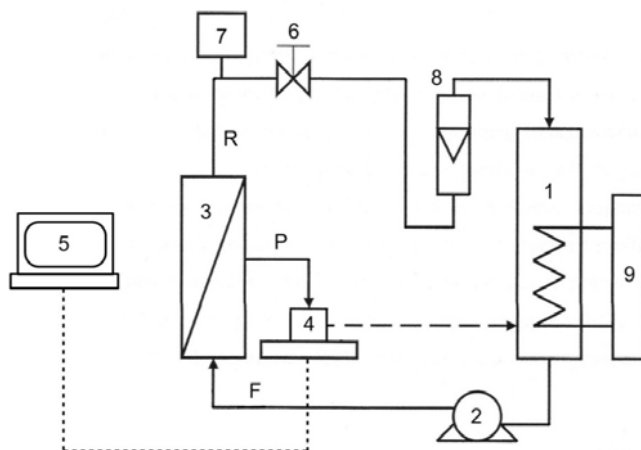

Fig. 2 Schematic diagram of the experimental equipment: 1 – storage tank, 2 – pump, 3 – membrane module, 4 – electronic balance, 5 – PC, 6 – regulating valve, 7 – manometer, 8 – flowmeter, 9 – thermoregulator; F – feed, P – permeate, R – retentate

0.02  $\mu\text{m}$  to 2000  $\mu\text{m}$ . The Mastersizer MU 2000 measured the scattered light intensity of the laser beam scattered on the particles in a sample. The Zetasizer Nano ZS then performed the particle size measurements with the aid of a process called dynamic light scattering (DLS). In this case, the device measured the Brownian motion of particles displaying it in relation to their size. The particle size of Zetasizer Nano ZS was measured in the range from 0.6 nm to 6  $\mu\text{m}$ .

## Results and Discussion

In order to select the optimum dose of coagulant, various doses were tested and their influence on cross-flow microfiltration process with respect to the steady-state values of permeate flux and particle size distribution studied.

The results of the experiments have shown that the coagulation could decrease the membrane fouling and increase the permeate flux. On the other hand, in some cases, coagulation could also decrease the permeate flux. Finally, the average particle size after coagulation can be increased but in some cases may be a particle size smaller than that in the case of the untreated dispersion material. This has shown the importance of the right selection of a coagulant.

### Pretreatment by PAM

The dependencies of flux-time curve on PAM dosage are gathered in Fig. 3. From this figure it is evident that the influence of PAM on the steady-state permeate flux is positive. In Fig. 3, we can also see that the optimal dose of PAM from the doses

tested is  $100 \text{ mg l}^{-1}$ . The results with higher dose ( $200 \text{ mg l}^{-1}$ ) are worse than those with the lower one, and even worse than for the experiment without pretreatment. Moreover, the results also show that polyacrylamide is not suitable for this system because of insignificant increase of the steady-state permeate flux even with the optimum dose of coagulant.

In Fig. 4, we can see the effect of PAM dosage on particle size distributions. Again, it is evident that the distribution curves for all concentrations of coagulant have a similar character. The results indicate that the dispersion with the highest concentration of coagulant ( $200 \text{ mg l}^{-1}$ ) contained smaller particles than dispersion without pretreatment. It can be explained by the fact that these small particles have the tendency to block (“clog”) the membrane pores. In Fig. 3, we could see that the clogging of the membrane pores caused a lower steady-state permeate flux during the membrane separation due to the high concentration of coagulant.

### Pretreatment by PACA

Figure 5 depicts the dependencies of flux-time curve on PACA dosage, illustrating the influence of PACA on the steady-state permeate flux is negative. It can also be seen that the steady state flux is increasing with higher coagulants dosage.

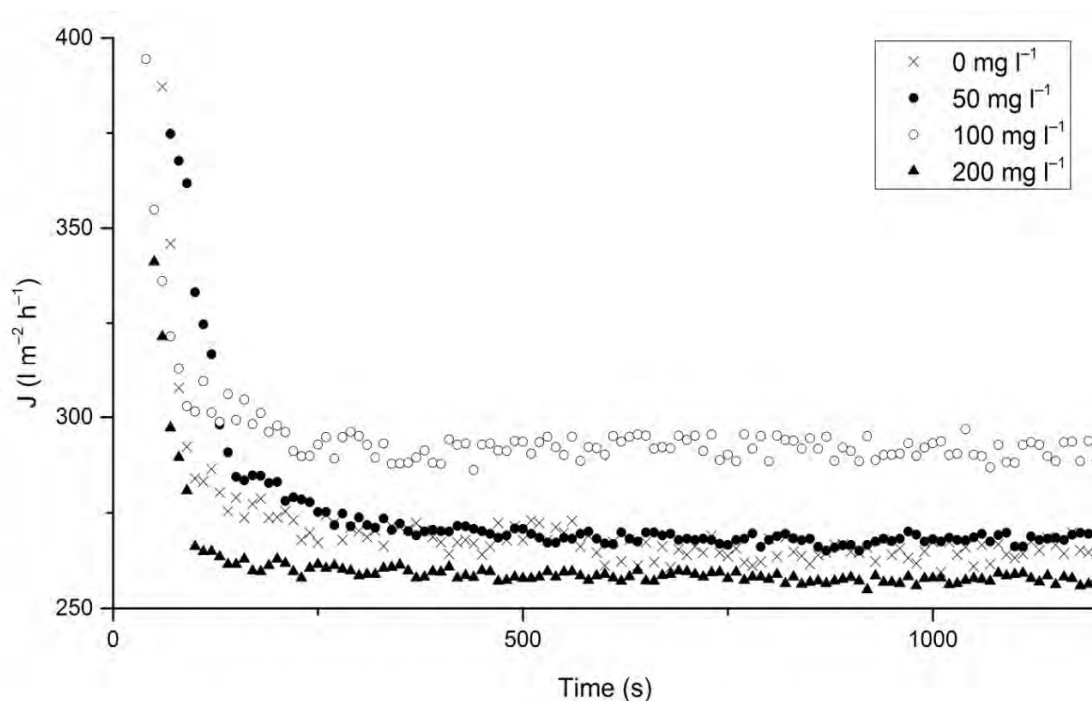

Fig. 3 Effect of PAM dosage on flux-time curve during of cross-flow microfiltration

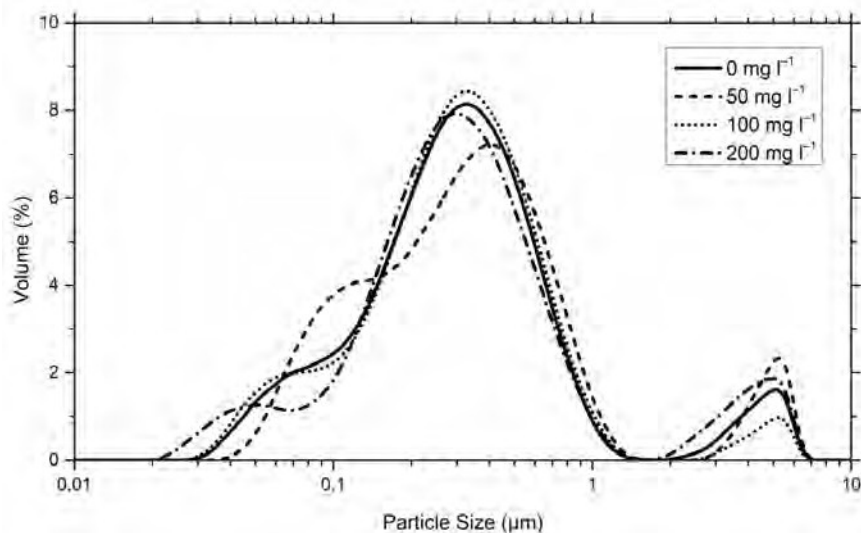

Fig. 4 Effect of PAM dosage on particle size distribution (measured by Zetasizer Nano ZS)

It can be stated that all the tested concentrations of coagulant were worse than those for the experiment without pretreatment. Thus, the coagulant PACA is not suitable for this system as it has reduced the steady-state permeate flux compared to the experiments without pretreatment.

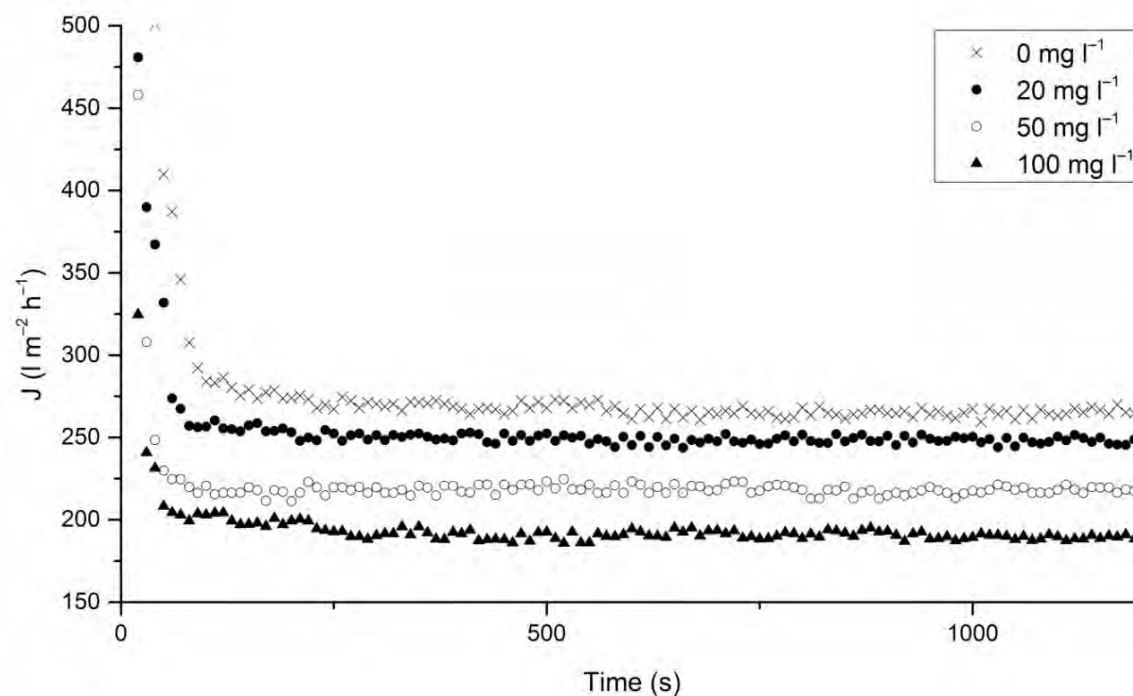

Fig. 5 Effect of PACA dosage on flux-time curve during of cross-flow microfiltration

In Fig. 6, we can see the effect of PACA dosage on particle size distributions. It is evident that the distribution curves, for the dispersion prepared using the coagulant, had different characteristics compared to the distribution curve of dispersion without pretreatment. Also, the distribution curves for all



concentrations of coagulant are similar in area of the main peak, except the case with small particle size, where the respective distribution differs from the same process for distribution curve of dispersion without pretreatment.

Dispersions pretreated by PACA coagulant contained smaller particles than the dispersion without pretreatment; namely, for concentrations of 20 and 50 mg l<sup>-1</sup> having the particle size between 20 and 50 nm. At the highest concentration of the coagulant (100 mg l<sup>-1</sup>) the dispersion contains particles with the size larger than 10 nm. This trend of increasing concentration of PACA coagulant produced smaller particles demonstrates why the increasing concentration of PACA coagulant gives rise to a decrease of the steady-state permeate flux.

Probably, this was caused by too small particles being smaller than the membrane pores and, therefore, it might cause the above-mentioned clogging. This effect of blocking the membrane pores by small particles then resulted in the lower steady state permeate flux of the pretreated dispersion compared to the experiment with dispersion without pretreatment.

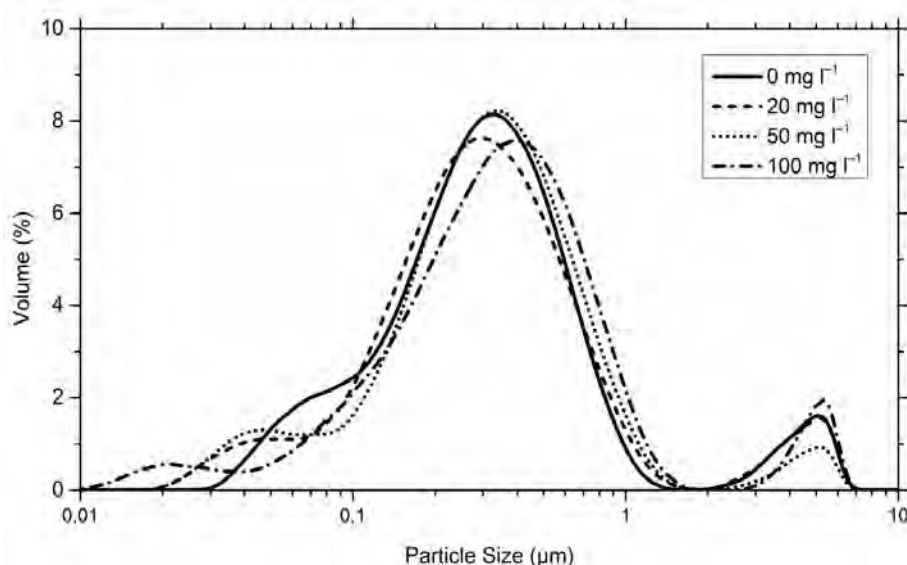

Fig. 6 Effect of PACA dosage on particle size distribution (measured by Zetasizer Nano ZS)

### Pretreatment by pDADMAC

The dependencies of flux-time curve on pDADMAC dosage are shown in Fig. 7. It documents the benefit of pDADMAC and its use in confrontation with other two types of coagulant. The figure also reveals that the optimum dose of pDADMAC is 30 mg l<sup>-1</sup>; nevertheless, the results with higher doses (40 mg l<sup>-1</sup> or 50 mg l<sup>-1</sup>, respectively) are very similar. Otherwise, the results also show that pretreatment of the feed by pDADMAC led to more than three-times higher permeate flux compared with the conditions without any pretreatment. It can be stated that the

application of a higher dose ( $100 \text{ mg l}^{-1}$ ) has led to worse results than for optimum dosing but still with better performance than experiments without pretreatment.

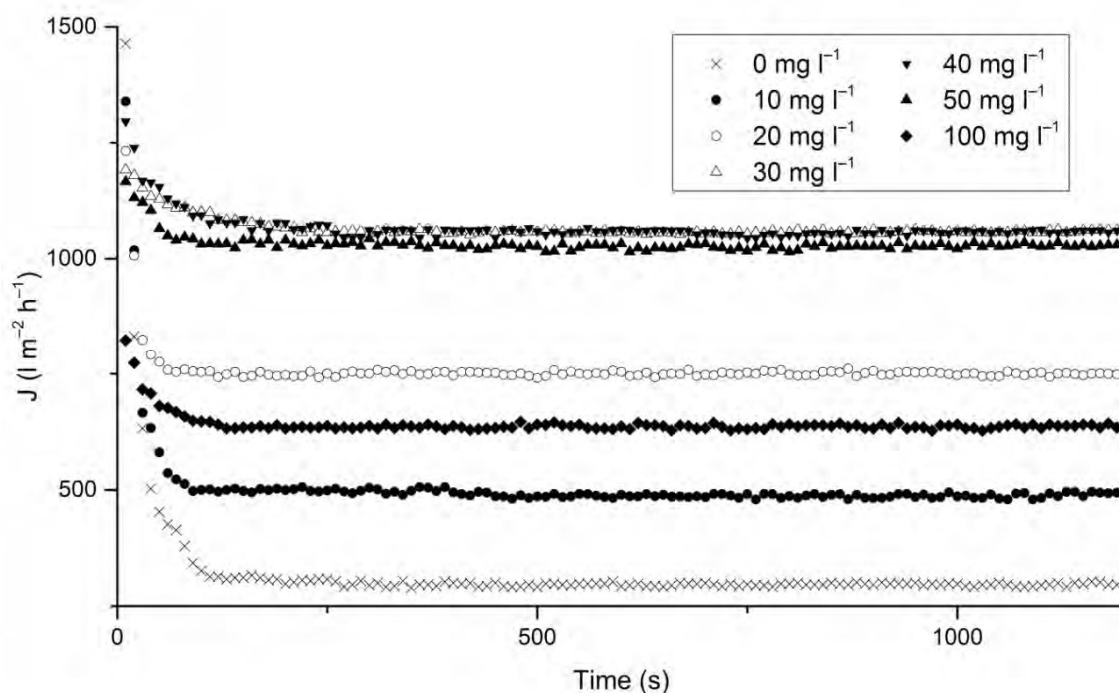

Fig. 7 Effect of pDADMAC dosage on flux-time curve during of cross-flow microfiltration

In Fig. 8, we can see the effect of pDADMAC dosage on the particle size distributions when the distribution curves for all concentrations of coagulant have similar characteristics but changed to lower or higher values of particle size. Also, the distribution curves for all concentrations of coagulant are significantly different from those for the dispersion without pretreatment.

Next, we have explored the effect of pDADMAC dosage on average particle size, which is plotted in Fig. 9. As can be seen, the particle size are highly variable with various concentrations of coagulant, when even the lowest concentration of coagulant has caused an abrupt increase in particle size.

The largest average particle size of the dispersion was at the optimum concentration of coagulant ( $30 \text{ mg l}^{-1}$ ). At this concentration, the average particle size was  $8.65 \text{ }\mu\text{m}$ , being eighteen-times higher than the average particle size in experiments without pretreatment.

At concentrations of coagulant higher than  $30 \text{ mg l}^{-1}$ , the particle size decreased down to lower values, confirming the microfiltration tests and the previously observed changes in the steady-state permeate fluxes.

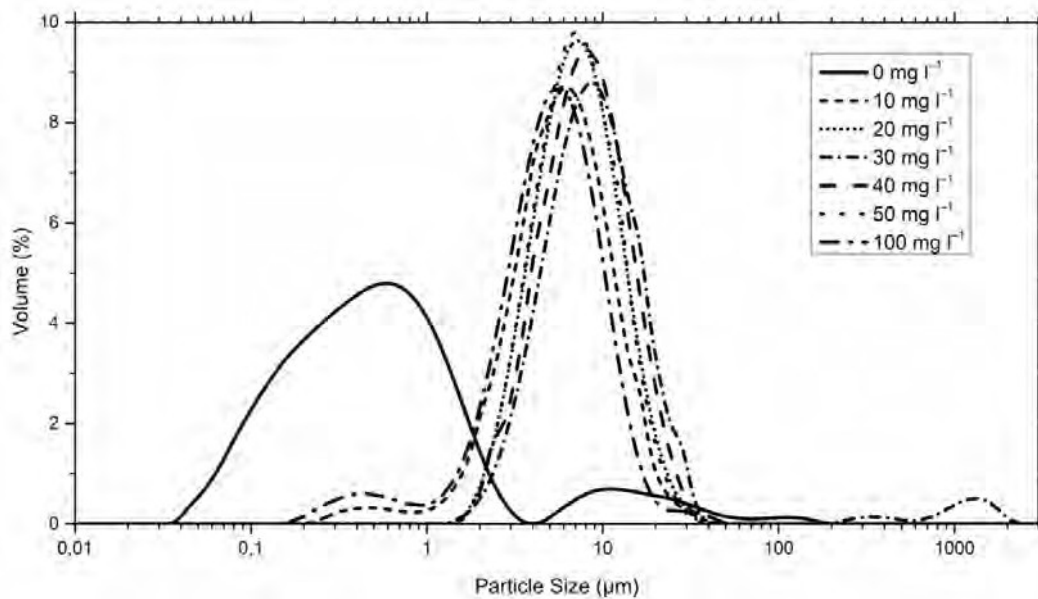

Fig. 8 Effect of pDADMAC dosage on particle size distribution (measured by Mastersizer MU 2000)

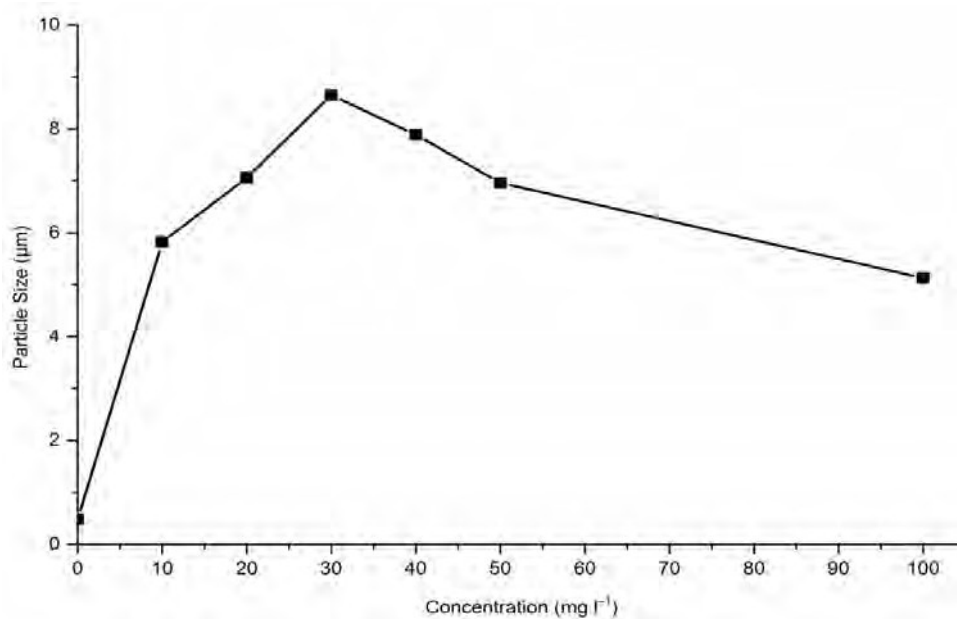

Fig. 9 Effect of pDADMAC dosage on average particle size (measured by Mastersizer MU 2000)

### Comparison of Coagulants

In Fig. 10, the dependencies of flux-time curve for the coagulants tested and their optimal dosage are shown. From this comparison, it is evident that more suitable coagulant for the system used is pDADMAC at the optimum dosage of 30 mg l<sup>-1</sup>. The other two coagulants did not show such improvements as pDADMAC, beca-

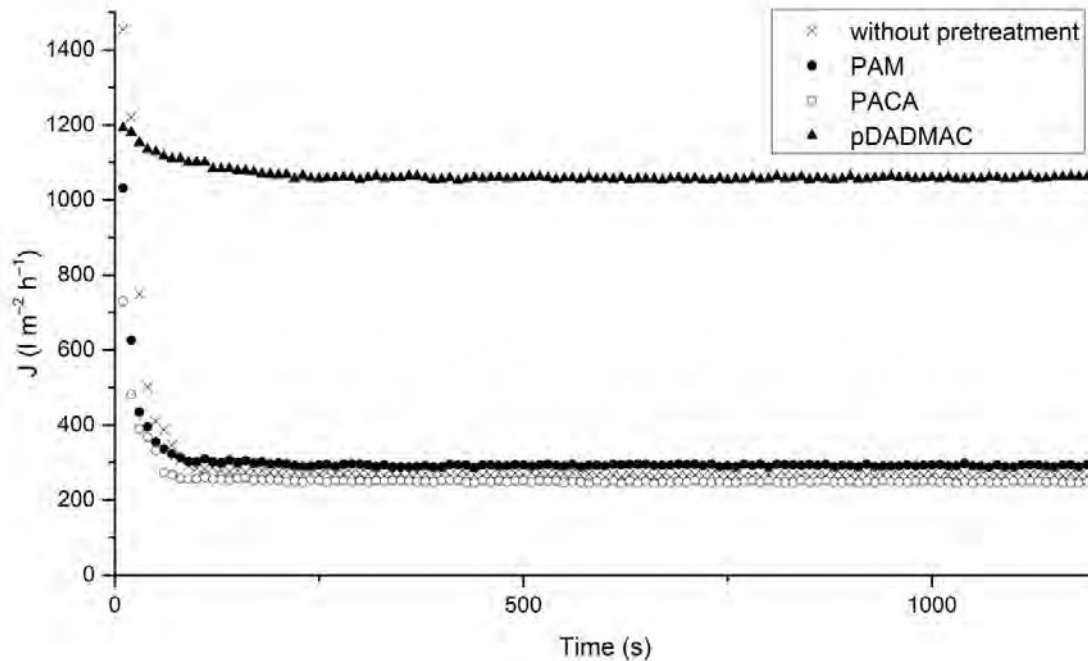

Fig. 10 Effect of coagulant addition at optimum dosage on flux-time curve during of cross-flow microfiltration

use the pretreatment by PAM and PACA had led only to insignificant enhancement of the permeate flux. Pretreatment of the feed by PAM resulted in negligibly improved, ca. 10 % higher permeate flux compared to that done without pretreatment while application of PACA led even to a lower permeate flux than without pretreatment. Thus, experimental results have revealed the need for careful selection of the coagulant, because different coagulants had considerably different impact on the permeate flux.

### Coagulation Mechanism

The main mechanism of coagulation involved in the removal of dissolved and particulate contaminants, which are often cited, are the charge neutralization, bridge formation, and electrostatic patch [19]. These mechanisms are principally dependent on the adsorption of coagulants (flocculants) on the particle surface [20].

Different coagulation ability of tested coagulants may be caused by different mechanism of coagulation. Tested coagulant pDADMAC is a cationic polymer with medium average molecular weight and a high charge density. Higher-charged polymers tend to produce flocs with higher particle size and due to that fact such higher-charged polymers induce electrostatic patch flocculation [21]. According to Blanco *et al.* [22], pDADMAC produces flocs by charge neutralization. In contrast, PAM is a polymer with low average molecular weight and low charge

density producing flocs by bridging [22]. Tested PAM having an average molecular weight of 10,000 is not suitable for this type of coagulation mechanism because for the effective bridging to be more efficient polymer having a higher molecular weight [23]. Experimental results show that there is no coagulation when using PACA as the coagulant.

### Preliminary Economic Evaluation

From the experiments, it is evident that the most suitable coagulant for the system measured is pDADMAC with the optimum dosage of  $30 \text{ mg l}^{-1}$ . The preliminary economic evaluation suggests us that the expenses associated with pretreatment operations in laboratory scale are not profitable, because the cost of the pDADMAC coagulant addition per  $1 \text{ m}^3$  of dispersion under these test conditions is 4.15 €. It means that the cost of the coagulant addition per 1 ton of  $\text{TiO}_2$  is 138 €.

Such a price could be significantly reduced in a large scale application, because of the fact that the price of a coagulant in large packs is significantly lower. The price of this coagulant in large packs is around 1200 € per ton of solution at a concentration of 40 %, which allows lower the costs of the coagulant addition per  $1 \text{ m}^3$  of treatment solution down to ca. 0.087 €. In other words, the costs of the coagulant addition per 1 ton of  $\text{TiO}_2$  could be even 2.9 €. This result is more interesting as well as more realistic in practical applications.

### Conclusion

The results of the experiments presented in the previous sections have shown that, during cross-flow membrane microfiltration of titanium dioxide dispersion, the values of steady-state permeate flux and the particle size distribution were significantly affected by the choice of the respective coagulant; pDADMAC, PAM, and PACA being of interest in this study. The use of coagulants could significantly decrease the membrane fouling, thus increasing the resultant permeate flux. The most suitable coagulant for the cross-flow microfiltration of titanium dioxide was pDADMAC and its optimum dosage was  $30 \text{ mg l}^{-1}$ . Pretreatment of the feed by  $30 \text{ mg l}^{-1}$  pDADMAC has led to more than three-times higher permeate flux than that without any pretreatment. The largest average particle size of the dispersion was found to be at the optimum concentration of  $30 \text{ mg l}^{-1}$  pDADMAC; the average particle size at the optimum concentration being  $8.65 \text{ }\mu\text{m}$ . This average particle size was eighteen-times higher than the average particle size of dispersion without pretreatment. The other two coagulants tested did not show such improvements as pDADMAC, when the optimum dosage of

PAM was 100 mg l<sup>-1</sup> but the feed pretreatment by this PAM dosage had led to only 10 percent higher permeate flux than in experiments without pretreatment. This is considerably lower permeate flux than that with pretreatment by pDADMAC. Regarding PACA, no optimum dosage was found because, for each dosage, pretreatment of the feed by PACA had always led to a lower permeate flux compared to that without pretreatment.

Based on the experiments performed, it can be concluded that the proper coagulant has to be carefully selected because its type and the actual dosage have both a principal impact on the resultant permeate flux.

## Acknowledgement

*This work was funded by University of Pardubice, grant No. SGSFChT\_2015006.*

## References

- [1] Lecjaks Z., Machač I., Kuchler M.: *Chemical Engineering I* (in Czech), 4<sup>th</sup> ed., the University of Pardubice, Pardubice, 2004.
- [2] Mulder M.: *Basic Principles of Membrane Technology*, 2<sup>nd</sup> ed., Kluwer Academic Publishers, Dordrecht, 1996.
- [3] Wang L.K., Chen J.P., Hung Y., Shammas N.K.: *Membrane and Desalination Technologies: Handbook of Environmental Engineering*, Humana Press, New York, 2011.
- [4] Mikulášek P., Doleček P., Šedá H., Cakl J.: *Dev. Chem. Eng. Miner. Process.* **2**, 115 (1994).
- [5] Mikulášek P. *et al.* (Doleček P., Jiráňková H., Kinčl J., Kočířík M., Pospíšil P., Schauer J.): *Pressure-driven Membrane Processes* (in Czech), Publishing house of the Institute of Chemical Technology, Prague, Prague, 2013.
- [6] Baruth E.: *Water Treatment Plant Design*, 4<sup>th</sup> ed., McGraw-Hill, New York, 2005.
- [7] Pabby A.K., Rizvi S.S. H., Sastre A. M.: *Handbook of Membrane Separations: Chemical, Pharmaceutical, Food, and Biotechnological Applications*, CRC Press, Boca Raton, 2008.
- [8] Erdei L., Chang C.Y., Vigneswaran S.: *Sep. Sci. Technol.* **43**, 1839 (2008).
- [9] Park C., Hong S.W., Tai H.C., Choi Y.S.: *Desalination.* **250**, 673 (2010).
- [10] Zhu H., Wen X., Huang X.: *Desalination.* **284**, 324 (2012).
- [11] Bhattacharya P., Dutta S., Ghosh S.: *Desalination.* **261**, 67 (2010).
- [12] Zhao B., Wang D., Li T., Chow C.W.K., Huang C.: *Sep. Purif. Technol.* **72**, 22 (2010).
- [13] Wang J., Guan J., Santiwong S.R., Waite D.T.: *J. Membr. Sci.* **321**, 132

- (2008).
- [14] Hofs B., Vries D., Siegers W.G., Beerendonk E.F, Cornelissen E.R.: *Desalination*. **299**, 28 (2012).
  - [15] Wang S., Liu C., Li Q.: *Water Res.* **45**, 357 (2011).
  - [16] Wu B., An Y., Li Y., Wong F.S.: *Desalination*. **242**, 183 (2009).
  - [17] Mikulášek P., Wakeman R.J., Marchant J.Q.: *Chem. Eng. J.* **69**, 53 (1998).
  - [18] Zakordonskiy V.P., Soltys M.N.: *Colloid J.* **76**, 416 (2014).
  - [19] Lee C.S., Robinson J., Chong M.F.: *Process Saf. Environ. Protect.* **92**, 489 (2014).
  - [20] Bolto B., Gregory J.: *Water Res.* **41**, 2301 (2007).
  - [21] Zhou Y., Franks G.V.: *Langmuir* **22**, 6775 (2006).
  - [22] Blanco A., Fuente E., Negro C., Tijero J.: *Can. J. Chem. Eng.* **80**, 734 (2002).
  - [23] Razali M.A.A., Ahmad Z., Ahmad M.S.B., Ariffin A.: *Chem. Eng. J.* **166**, 529 (2011).